

FAST EVO

User's manual

Installation and Servicing instructions

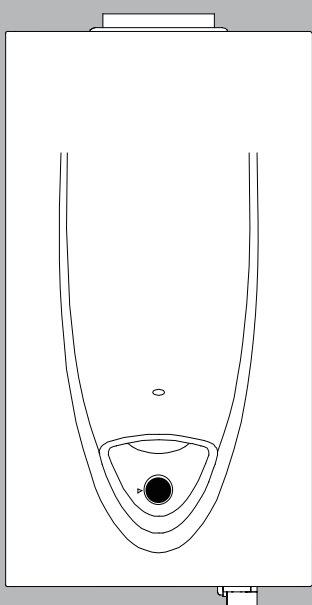

INSTANTANEOUS GAS
WATER HEATER

TYPE: B

FAST EVO ONT B 11

FAST EVO ONT B 14

FAST EVO ONT B 16

WARNING
TO BE INSTALLED BY APPROVED

Important:

Read these instructions for use carefully so as to familiarize yourself with the appliance before concerning it to its gas container. Keep these instructions for future reference.

User's manual

General warnings	3
Safety regulations.....	4
Control panel	5
Battery insertion.....	5
Battery replacement	5
Ignition procedure.....	6
Appliance power adjustment and water temperature adjustment	6
Switching off procedure	6
Appliance shut-off conditions.....	7
Anti-freeze protection	7
Maintenance	7

Dear Customer,

Thank you for choosing an ARISTON gas water heater. We guarantee that your instantaneous water heater is a reliable and technically sound product. This manual provides detailed instructions and recommendations for proper installation, use and maintenance. Remember to keep this manual in a safe place for future reference i.e. by the gas meter. Your local ARISTON Servicing Centre is at your complete disposal for all requirements.

FOR YOUR SAFETY

“Important: Read these instructions for use carefully so as to familiarize yourself with the appliance before connecting it to its gas container. Keep these instructions for future reference”.

IF YOU SMELL GAS:

- * Turn off gas supply at bottle
- * Extinguish all naked flames;
- * Do not operate any electrical appliances
- * Ventilate the area
- * Check for leaks as detailed in this manual

If odour persists, contact your dealer or gas supplier immediately

Do not tamper or modify the appliance.

BURN-BACK (FIRE IN BURNER TUBE OR CHAMBER)

In the event of a burn-back, where the flame burns back to the jet, immediately turn the gas supply off at the control valve on the panel. After ensuring the flame is extinguished, wait for 1 minute and re-light the appliance in the normal manner. Should the appliance again burn back, close the control valve and call a service technician. Do not use the appliance again until the service technician has declared that it is safe to do so.

GAS-PRESSURE REGULATOR

This appliance requires an operating pressure of 2,8 kPa at the appliance. A suitable LPG regulator that complies with the requirements of SANS 1237 must be installed.

IMPORTANT INFORMATION FOR THE USER

This appliance may only be installed by a registered SAQCC Gas installer. All registered installers are issued with a card carrying their registration number. Ask to be shown the card before allowing the installation work to commence and make a note of the Installer registration number. Upon completion of the installation, the installer is required to explain the operational details of the appliance together with the safety instructions. You will be asked to sign acceptance of the installation and be provided with a completion certificate. You should only sign for acceptance of the installation when the installation is completed to your satisfaction.

Note that your invoice is required in the event that you wish make a guarantee claim.

IMPORTANT INFORMATION FOR THE INSTALLER.

This appliance may only be installed by a gas installer registered with the South African qualification and certification committee (SAQCC). The appliance must be installed in accordance with the requirements of SANS 10087-1 for use with LPG, SANS 827 for use with NG and any fire department regulations and/or local bylaws applicable to the area. If in doubt, check with the relevant authority before undertaking the installation. Upon completion of the installation you are required to fully explain and demonstrate to the user the operational details and safety practices applicable to the appliance and the installation.

THIS BOOK (USER'S AND INSTALLATION MANUAL) IS AN INTEGRAL AND ESSENTIAL COMPONENT OF THE PRODUCT. MUST BE KEPT CAREFULLY BY YOU AND WILL ALWAYS ACCOMPANY THE APPLIANCE IN THE EVENT OF ITS SALE TO ANOTHER OWNER OR USER AND / OR TRANSFER TO ANOTHER INSTALLATION. CAREFULLY READ THE INSTRUCTIONS AND WARNINGS CONTAINED IN THIS MANUAL AS IT CONTAIN IMPORTANT INFORMATION ABOUT SAFE INSTALLATION, OPERATION AND MAINTENANCE

This appliance is designed to produce hot water for domestic use.

It should be connected to a distribution network for domestic hot water that must be compatible with its performance and power levels.

The use of the appliance for purposes other than those specified is strictly forbidden. The manufacturer cannot be held responsible for any damage caused by improper, incorrect and unreasonable use of the appliance or by the failure to comply with the instructions given in this manual.

Installation, maintenance and all other interventions must be carried out in full conformity with the governing legal regulations and the instructions provided by the manufacturer.

Incorrect installation can harm persons, animals and possessions; the manufacturing company shall not be held responsible for any damage caused as a result.

In the event of a fault and/or malfunction, turn the appliance off, turn off the gas cock, remove the batteries and do not attempt to repair it yourself. Contact a qualified professional instead.

All repairs, which should only be performed using original spare parts, should be carried out by a qualified professional. Failure to comply with the above instructions could compromise the safety of the appliance and invalidate all liability on the part of the manufacturer

In the event of any maintenance or other structural work in the immediate vicinity of the ducts or flue gas exhaust devices and their accessories, switch the appliance off, remove the batteries and shutting off the gas control valve.

When the work has been completed, ask a qualified technician to check the efficiency of the ducting and the devices.

If the appliance should be out of use for a prolonged period, it is recommended that the external gas cock be closed and the batteries are removed. If low temperatures are expected, the appliance and system pipe work should be drained in order to prevent frost damage.

When permanently deactivating the appliance, make sure that the operations are carried out by qualified technical professional.

Turn the appliance off and remove the batteries to clean the exterior parts of the appliance.

No inflammable items should be left or used in the vicinity of the appliance.

WARNING!!



Water with a temperature higher than 50° cause serious burns. Always verify water temperature before use.

IMPORTANT!



If the unit is installed in areas with the presence of hard water (> 200 mg / l) is necessary to install a water softener to reduce the precipitation of limestone in the heat exchanger. The warranty does not cover damage caused by the limestone.

WARNING!!



This appliance is not intended for use by persons (including children) with reduced physical, sensory or mental capabilities, or lack of experience and knowledge, unless they have been given supervision or instruction concerning use of the appliance by a person responsible for their safety.

Children should be supervised to ensure that they do not play with the appliance.

WARNING!!



The device must be activated only in presence of water in the exchanger.

Safety regulations

Key to symbols:

Failure to comply with this warning implies the risk of personal injury, in some circumstances even fatal



Failure to comply with this warning implies the risk of damage, in some circumstances even serious, to property, plants or animals.



Do not perform operations which involve opening the appliance.

Electrocution from live components.

Personal injury caused by burns due to overheated components, or wounds caused by sharp edges or protrusions.



Do not perform operations which involve removing the appliance from its installation space .

Electrocution from live components.

Flooding caused by water leaking from disconnected piping.



Explosions, fires or intoxication caused by gas leaking from disconnected piping.



Do not damage the power supply cable.

Electrocution from live uninsulated wires.



Do not leave anything on top of the appliance.

Personal injury caused by an object falling off the appliance as a result of vibrations.



Damage to the appliance or items underneath it caused by the object falling off as a result of vibrations.



Do not climb onto the appliance.

Personal injury caused by the appliance falling.



Damage to the appliance or any objects underneath it caused by the appliance falling away from its installation space.



Do not climb onto chairs, stools, ladders or unstable supports to clean the appliance.

Personal injury caused by falling from a height or cuts (stepladders shutting accidentally).



Do not attempt to clean the appliance without first switching it off and turning the external switch to the OFF position.

Electrocution from live components.



Do not use insecticides, solvents or aggressive detergents to clean the appliance.

Damage to plastic and painted parts.



Do not use the appliance for any use other than normal domestic use.

Damage to the appliance caused by operation overload.



Damage caused to objects treated inappropriately.

Do not allow children or inexperienced individuals to operate the appliance.

Damage to the appliance caused by improper use.



If you detect a smell of burning or smoke coming from the appliance, disconnect it from the electricity supply, turn off the main gas valve, open all windows and call for assistance.

Personal injury caused by burns, smoke inhalation, intoxication.



If there is a strong smell of gas, turn off the main gas valve, open all windows and call for assistance.

Explosions, fires or intoxication.



WARNING

Installation, first ignition and maintenance work must be performed by qualified personnel only, in accordance with the instructions provided.

Incorrect installation may harm individuals, animals or property; the manufacturer will not be held responsible for any damage caused as a result.

If the appliance is installed inside the apartment, make sure that all provisions relating to the air inlet and room ventilation (in compliance with current legislation) are respected.

Battery replacement

- unhook the battery compartment cover placed on the bottom of the appliance
- remove the battery and replace observing the polarities indicated on the device.

ATTENTION!!

Used batteries can not be dispersed in the environment

Used batteries can not be utilized.

Control pannel

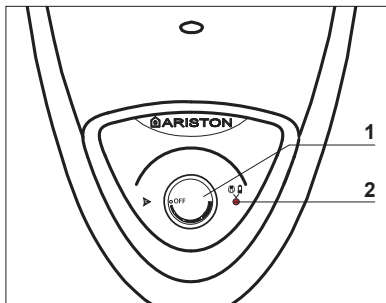

- 1 - Switch ON/OFF and D.H.W temperature knob
- 2 - Red L.E.D.:
 - errors signal
 - replace battery

Battery insertion

- unhook the battery compartment cover placed on the bottom of the appliance
- Insert 2 batteries (1,5V LR20) in the appropriate compartment while observing the polarities indicated on the device.

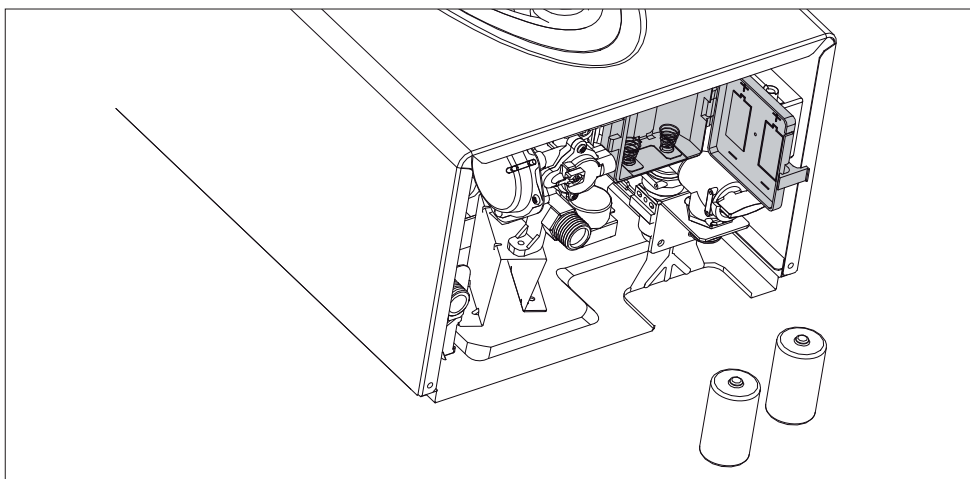

Ignition procedure

- ensure that the cock located on the cold water fitting is open
- ensure that the gas cock is open
- make sure the batteries provided (1.5V LR20) were correctly inserted.
- Turn the knob between the positions of minimum and maximum.

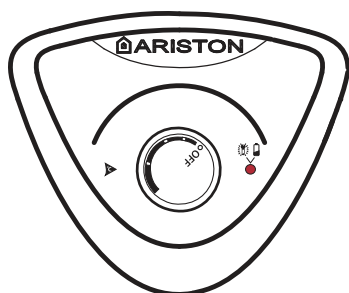
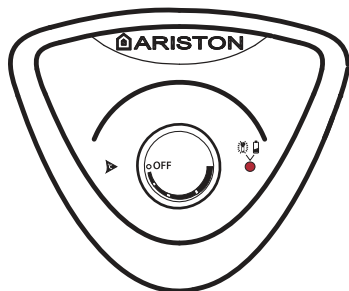

The device is ready to operate

By opening a tap, the device automatically starts operating.

Note: If the device does not operate, ensure that the gas and/or cold water cocks are open.

Ensure that the device is electrically powered.

Make sure the batteries were inserted.

When closing the tap, the device automatically switches off.



WARNING!!

Water with a temperature higher than 50°C can cause serious burns.

Always verify water temperature before use.

Appliance power and Water temperature adjustment

The knob lets you adjust the water temperature and power:

- Turn clockwise to increase power and temperature
- Turn anticlockwise to decrease power and temperature.

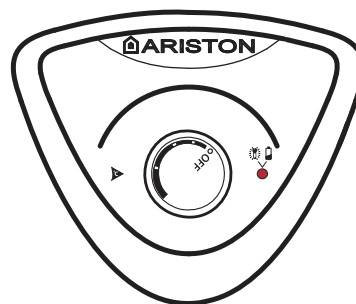

Switching off procedure

Turn the knob to OFF position to switch off the appliance.

To switch off the device completely, switch off and close the gas isolation valve.

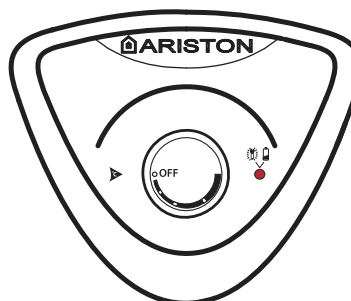

Appliance shut-off conditions

The appliance is protected from malfunctions by means of internal checks performed by the electronic P.C.B., which stops the appliance from operating if necessary. In the event of lockout, the red LED lights - see table below.

To restore the system, switch ON/OFF the device.

Error code table

Red ● L.E.D.	Description	Checks to make
Fixed	Battery exhausted	Replace battery
Single flash	No hot water produced The appliance won't start	<ul style="list-style-type: none"> - Ensure that the gas isolation valve is open - Ensure that the inlet water isolation valve is open - Ensure the knob is not in OFF position - Check/Replace batteries
Double flash	Switch OFF the appliance - turn the knob to the OFF position, close the gas valve, remove the batteries. Contact a qualified technician.	
Three flashes		
Four flashes		
Five flashes		

If the appliance won't start again or stops repeatedly, once you've carried out the relevant checks, turn the knob to the OFF position, close the gas valve, remove the batteries and contact a qualified technician.

SHOULD THE ERROR NOT BE ELIMINATED, DO NOT ACTIVATE THE APPLIANCE.



WARNING!!

NEVER TAMPER WITH OR DECOMMISSION THE FLUE GAS SENSOR. THIS COULD AFFECT THE PROPER OPERATION OF THE APPLIANCE. POOR DRAUGHT CONDITIONS COULD CAUSE EXHAUST GAS BACKFLOW INTO THE INSTALLATION ROOM. HAZARD OF CARBON MONOXIDE INTOXICATION

Temporary Shut-Off due to defective flue gas discharge

This device causes the appliance to shut down in the event of an anomaly in the flue gas discharge.

The appliance shutdown is temporary.

After 12 minutes, the appliance begins the ignition procedure; if normal conditions have been restored, the appliance operates as normal. If not, it shuts down and the cycle is repeated.

WARNING

In the event of a malfunction or if repeated intervention is required:

- switch the appliance off,
- close the gas valve,
- remove the batteries,
- contact the Technical Assistance Service or a qualified technician in order to repair the flue gas discharge fault once the cause of the malfunction is detected.

Whenever maintenance work is performed on the device, use original spare parts only and follow the relative instructions carefully.

Anti-freeze protection

Should the appliance be installed where pipes are subjected to freezing, it is recommended to empty it.

Proceed as indicated below:

- Turn the knob to OFF position to switch off the appliance.
- Remove the batteries
- Close the cold water inlet isolation valve
- Open the DHW taps until both the appliance and pipes are completely emptied.

To fill the appliance again, open the cold water inlet isolation valve together with DHW taps until water flows steadily from all taps.

Maintenance

Schedule an annual maintenance check-up for the appliance with a competent person.

Correct maintenance always results in savings in the cost of running the system.

Installation and servicing instructions **(Only for qualified technician)**

overview	9
Advice for the installer	9
Safety regulations.....	10
product description	11
Overall view	11
Water circuit diagram.....	11
Dimensions.....	12
Minimum clearances.....	12
Thecnical data	13
installation	14
Before installing the appliance.....	14
Installation location	14
Gas connection.....	14
Water connection.....	15
View of hydraulic connections	15
Connection to a solar installation.....	15
Connections of flue gas discharge ducts.....	15
Electrical diagram	16
commissioning	18
Ignition procedure.....	18
Electricity supply.....	18
Filling the hydraulic circuit	18
Gas supply.....	18
First Ignition	18
Checking the gas settings	19
Supply presure check	19
Checking the maximum and minimum burner pressure.....	19
Checking slow ignition power	19
Gas settins table.....	20
appliance protection devices	21
Table summarising error codes	21
maintenance	22
Instruction for opening the casing and performing an internal inspection.....	22
General comments	22
Operational test	23
Draining procedures	23
Information for the user	23

IMPORTANT INFORMATION FOR THE INSTALLER.

This appliance may only be installed by a gas installer registered with the South African qualification and certification committee (SAQCC). The appliance must be installed in accordance with the requirements of SANS 10087-1 for use with LPG, SANS 827 for use with NG and any fire department regulations and/or local by laws applicable to the area. If in doubt, check with the relevant authority before undertaking the installation. Upon completion of the installation you are required to fully explain and demonstrate to the user the operational details and safety practices applicable to the appliance and the installation.

 **Advice for the installer**

The installation and first ignition of the appliance must be performed by qualified personnel in compliance with current national regulations regarding installation, and in conformity with any requirements established by local authorities and public health organisations.

This appliance is designed to produce hot water for domestic use.

It should be connected to a distribution network for domestic hot water that must be compatible with its performance and power levels.

The use of the appliance for purposes other than those specified is strictly forbidden. The manufacturer cannot be held responsible for any damage caused by improper, incorrect and unreasonable use of the appliance or by the failure to comply with the instructions given in this manual.

Installation, maintenance and all other interventions must be carried out in full conformity with the governing legal regulations and the instructions provided by the manufacturer.

Incorrect installation can harm persons, animals and possessions; the manufacturing company shall not be held responsible for any damage caused as a result.

The appliance is delivered in a carton. Once you have removed all the packaging, make sure the appliance is intact and that no parts are missing. If this is not the case, please contact your supplier.

Keep all packaging material (clips, plastic bags, polystyrene foam, etc.) out of reach of children as it may present a potential hazard.

In the event of a fault and/or malfunction, turn the appliance off, turn off the gas cock, remove the batteries and do not attempt to repair it yourself. Contact a qualified professional instead.

All repairs, which should only be performed using original spare parts, should be carried out by a qualified professional. Failure to comply with the above instructions could compromise the safety of the appliance and invalidate all liability on the part of the manufacturer.

In the event of any maintenance or other structural work in the immediate vicinity of the ducts or flue gas exhaust devices and their accessories, switch OFF the appliance remove the batteries and shutting off the gas control valve.

When the work has been completed, ask a qualified technician to check the efficiency of the ducting and the devices.

Turn the appliance OFF and remove the batteries to clean the exterior parts of the appliance.

Clean using a cloth dampened with soapy water. Do not use aggressive detergents, insecticides or toxic products.

If the appliance is used in full compliance with current legislation, it will operate in a safe, environmentally-friendly and cost-efficient manner.

If using kits or optional extras, make sure they are authentic.

 **WARNING!!**

**Water with a temperature higher than 50°C can cause serious burns.
Always verify water temperature before use.**

 **WARNING!!**

NEVER TAMPER WITH OR DECOMMISSION THE FLUE GAS SENSOR. THIS COULD AFFECT THE PROPER OPERATION OF THE APPLIANCE. POOR DRAUGHT CONDITIONS COULD CAUSE EXHAUST GAS BACKFLOW INTO THE INSTALLATION ROOM. HAZARD OF CARBON MONOXIDE INTOXICATION

 **WARNING!!**

The device must be activated only in presence of water in the exchanger.

overview

Safety regulations

Key to symbols:



Failure to comply with this warning implies the risk of personal injury, in some circumstances even fatal



Failure to comply with this warning implies the risk of damage, in some circumstances even serious, to property, plants or animals.

Install the appliance on a solid wall which is not subject to vibration.



Noisiness during operation.

When drilling holes in the wall for installation purposes, take care not to damage any electrical wiring or existing piping.



Electrocution caused by contact with live wires. Explosions, fires or asphyxiation caused by gas leaking from damaged piping.



Damage to existing installations. Flooding caused by water leaking from damaged piping.

Perform all electrical connections using wires which have a suitable section.



Fire caused by overheating due to electrical current passing through undersized cables.

Protect all connection pipes and wires in order to prevent them from being damaged.



Electrocution caused by contact with live wires. Explosions, fires or asphyxiation caused by gas leaking from damaged piping.



Flooding caused by water leaking from damaged piping.

Make sure the installation site and any systems to which the appliance must be connected comply with the applicable norms in force.



Electrocution caused by contact with live wires which have been installed incorrectly.



Damage to the appliance caused by improper operating conditions.

Use suitable manual tools and equipment (make sure in particular that the tool is not worn out and that its handle is fixed properly); use them correctly and make sure they do not fall from a height. Replace them once you have finished using them.



Personal injury from the falling splinters or fragments, inhalation of dust, shocks, cuts, pricks and abrasions. Damage to the appliance or surrounding objects caused by falling splinters, knocks and incisions.



Use electrical equipment suitable for its intended use (in particular, make sure that the power supply cable and plug are intact and that the parts featuring rotary or reciprocating motions are fastened correctly); use this equipment correctly; do not obstruct passageways with the power supply cable, make sure no equipment could fall from a height. Disconnect it and replace it safely after use.



Personal injury caused by falling splinters or fragments, inhalation of dust, knocks, cuts, puncture wounds, abrasions, noise and vibration.



Damage to the appliance or surrounding objects caused by falling splinters, knocks and incisions.

Make sure any portable ladders are positioned securely, that they are suitably strong and that the steps are intact and not slippery and do not wobble when someone climbs them. Ensure someone provides supervision at all times.



Personal injury caused by falling from a height or cuts (stepladders shutting accidentally).

Make sure any rolling ladders are positioned securely, that they are suitably strong, that the steps are intact and not slippery and that the ladders are fitted with handrails on either side of the ladder and parapets on the landing.



Personal injury caused by falling from a height.

During all work carried out at a certain height (generally with a difference in height of more than two metres), make sure that parapets are used to surround the work area or that individual harnesses are used to prevent falls. The space where any accidental fall may occur should be free from dangerous obstacles, and any impact upon falling should be cushioned by semi-rigid or deformable surfaces.



Personal injury caused by falling from a height.

Make sure the workplace has suitable hygiene and sanitary conditions in terms of lighting, ventilation and solidity of the structures.



Personal injury caused by knocks, stumbling etc.

Protect the appliance and all areas in the vicinity of the work place using suitable material.



Damage to the appliance or surrounding objects caused by falling splinters, knocks and incisions.

Handle the appliance with suitable protection and with care.



Damage to the appliance or surrounding objects from shocks, knocks, incisions and squashing.

During all work procedures, wear individual protective clothing and equipment.



Personal injury caused by electrocution, falling splinters or fragments, inhalation of dust, shocks, cuts, puncture wounds, abrasions, noise and vibration.

Place all debris and equipment in such a way as to make movement easy and safe, avoiding the formation of any piles which could yield or collapse.



Damage to the appliance or surrounding objects from shocks, knocks, incisions and squashing.

All operations inside the appliance must be performed with the necessary caution in order to avoid abrupt contact with sharp parts.



Personal injury caused by cuts, puncture wounds and abrasions.

Reset all the safety and control functions affected by any work performed on the appliance and make sure they operate correctly before restarting the appliance.



Explosions, fires or asphyxiation caused by gas leaks or an incorrect flue gas exhaust. Damage or shutdown of the appliance caused by out-of-control operation.



Before handling, empty all components that may contain hot water, carrying out any bleeding if necessary.



Personal injury caused by burns.

Descal the components, in accordance with the instructions provided on the safety data sheet of the product used, airing the room, wearing protective clothing, avoid mixing different products, and protect the appliance and surrounding objects.



Personal injury caused by acidic substances coming into contact with skin or eyes; inhaling or swallowing harmful chemical agents.



Damage to the appliance or surrounding objects due to corrosion caused by acidic substances.

If you detect a smell of burning or smoke, keep clear of the appliance, disconnect it from the electricity supply, open all windows and contact the technician.



Personal injury caused by burns, smoke inhalation, asphyxiation.



WARNING!!

Never tamper with or decommission the flue gas sensor. This could affect the proper operation of the appliance.

Poor draught conditions could cause exhaust gas backflow into the installation room.

Hazard of carbon monoxide intoxication.

This appliance is not intended for use by persons (including children) with reduced physical, sensory or mental capabilities, or lack of experience and knowledge, unless they have been given supervision or instruction concerning use of the appliance by a person responsible for their safety.

Children should be supervised to ensure that they do not play with the appliance.

Overall view

Water circuit diagram

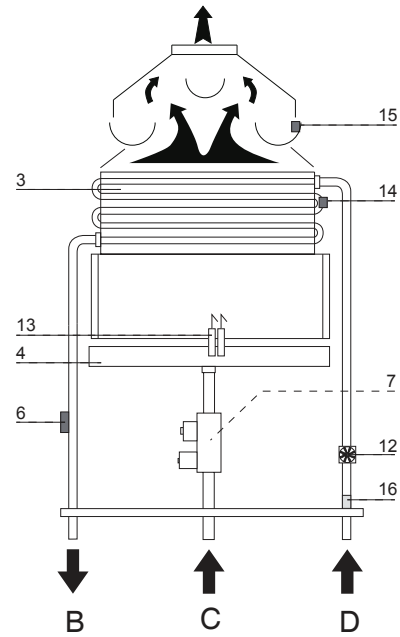
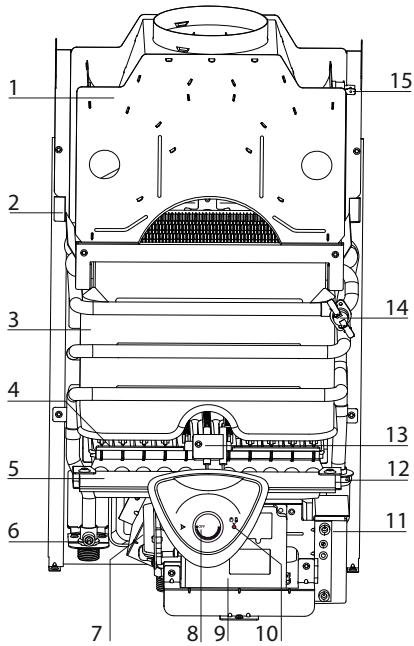

1. Combustion Hood
2. Frame
3. Heat exchanger
4. Burner
5. Gas collector
6. Hot water temperature sensor
7. Gas valve
8. Switch ON/OFF and D.H.W temperature knob
9. P.C.B. box
10. L.E.D.:
red - errors signal
orange - adjustment in progress
11. Ignition P.C.B.
12. Water flow switch
13. Ignition and detection electrode
14. Overheat thermostat
15. Fume sensor
16. Cold water inlet filter

- B.** Hot water outlet 1/2"
C. Ingresso Gas 1/2"
D. Cold water inlet 1/2"

product description

Overall dimensions

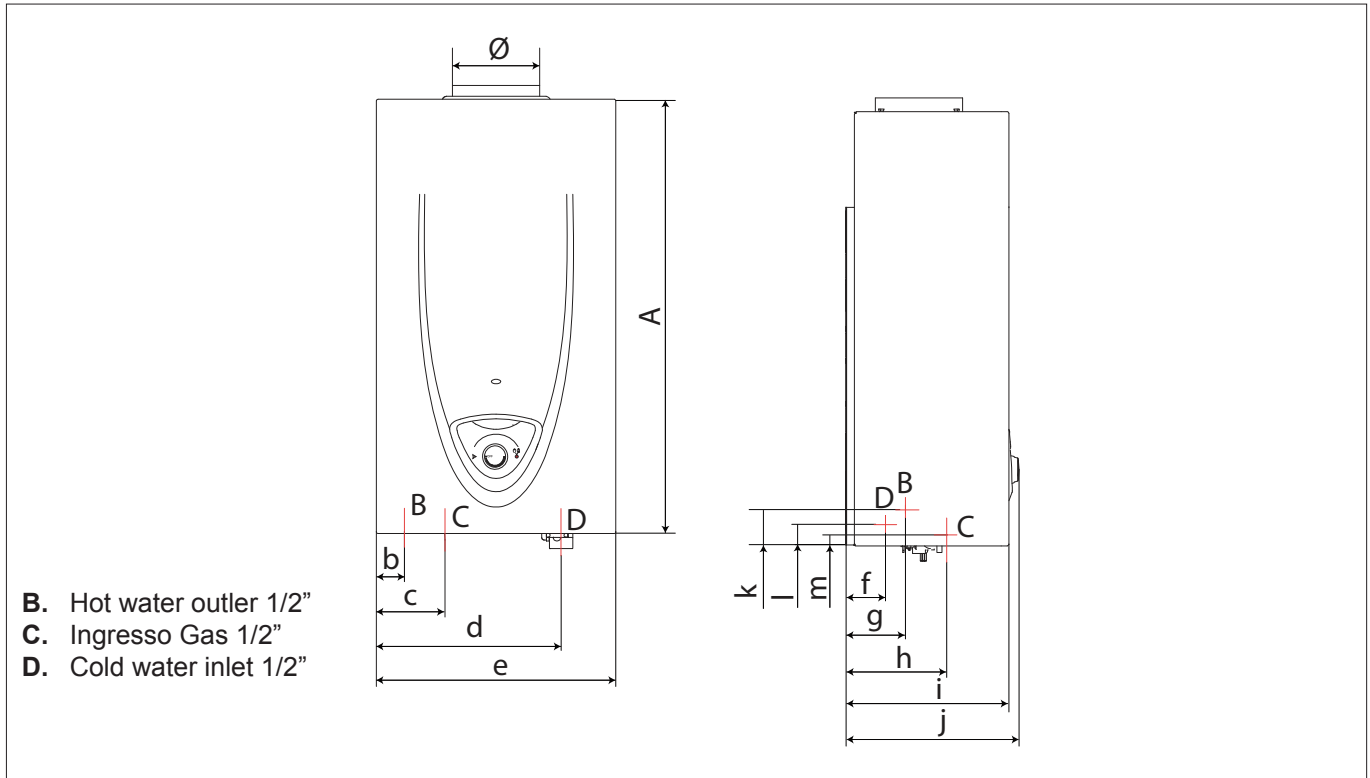

Model	Ø	a	b	c	d	e	f	g	h	i	j	k	l	m	weight	
															gross	net
11 l	113	580	37	87	228,5	310	54	58,8	131,5	210	230	25	16	22,5	9,6	8,9
14 l	132		70	117	264	370	48			230	250	23	11,2		11,0	10,2
16 l																

Minimum clearances

In order to allow easy access to the appliance for maintenance operations. The appliance must be installed in accordance with the clearances stated below.

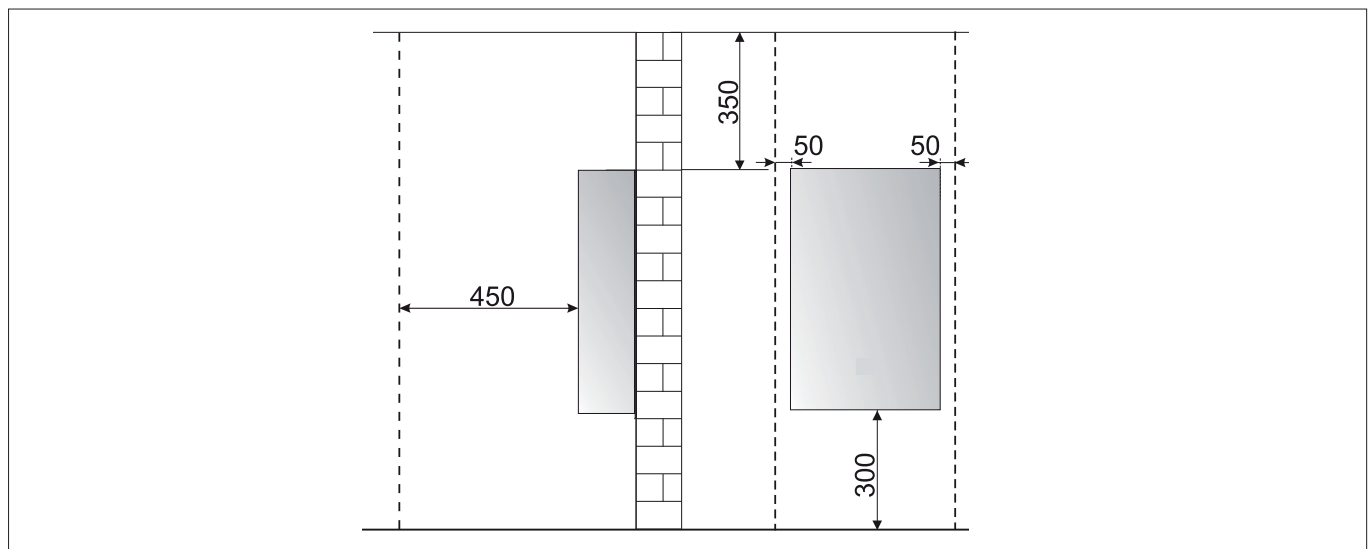

Technical Data

Model name : FAST EVO ONT B		11	14	16
Type		B		
Gas category		LPG		
Maximum nominal heat input	kW	21.5	27.0	31.0
Minimum nominal heat input	kW	9.5	10.5	10.5
Maximum nominal heat output	kW	19.0	24.0	27.5
Minimum nominal heat output	kW	8.0	9.0	9.0
D.H.W. max temperature	°C	65	65	65
D.H.W. min temperature	°C	35	35	35
D.H.W. Nominal flow rate	l/min	11	14	16
D.H.W. Minimum flow rate	l/min	>2	>3	>3
Water pressure maximum	bar	10	10	10
Water pressure minimum	bar	>0.1	>0.1	>0.1
Required flow rate - combustion air	m3/h	35.9	45.4	45.8
Flue fumes temperature at Minimum nominal heat input	°C	190	190	190
MAX capacity fumes (G20)	g/s	13.4	16.9	17.5
Minimum operating room temperature	°C	+5	+5	+5
Dimensions:				
Height		580	580	580
Width		310	370	370
Depth		210	230	230
Electricity supply - Batteries		2x1.5V LR20		
Ignition		by means of electric sparks		

installation

Before installing the appliance

The appliance heats water to a temperature below boiling. It should be connected to a domestic water mains supply, that must correspond in size to the performance and its power of the appliance.

Before connecting the appliance, it is first necessary to perform the following operations:

- Carefully wash the system piping in order to remove any screw thread or welding residues, or any dirt which might prevent the appliances from operating correctly.
- Make sure that the appliance is set up for operation with the type of gas available (read the information on the packaging label and on the boiler data plate).
- Make sure that there are no obstacles inside flue exhaust and that it does not contain any discharge from other appliances, unless the flue is meant to serve more than one user (in accordance with current legal requirements).
- Where there is already a connection to existing flue exhausts, check that these exhausts have been perfectly cleaned and are without residues, because any disconnection could obstruct the passage of fumes and create potentially dangerous situations.
- Make sure that, where unsuitable flue exhausts are attached, they have been ducted.
- In areas with particularly hard water, limescale may build up on the components inside the appliance and reduce its overall efficiency.

B11bs-type appliances are open-chamber versions designed to be connection to a flue gas discharge duct which releases fumes towards the outside; combustion air is taken directly from inside the room in which the boiler is installed.

Flue gas is discharged through a natural draught system.

This type of appliance cannot be installed in a room that does not meet appropriate ventilation requirements.

So that the normal operation of the appliance is not compromised, the place in which it is installed must be suitable with regard to the operating limit temperature value and the appliance should be protected so that it does not come into direct contact with atmospheric agents.

The appliance must be installed on a solid, non-combustible, permanent wall to prevent access from the rear.

When creating a space for the boiler, the minimum distances (which ensure that various parts of the appliance may be accessed after it has been installed) should be respected.



WARNING!!

The installation and first ignition of the appliance must be performed by qualified personnel in compliance with current national regulations regarding installation, and in conformity with any requirements established by local authorities and public health organisations.



WARNING!!

No inflammable items should be left in the vicinity of the appliance.

Make sure the installation site and any systems to which the appliance must be connected are fully compliant with the current applicable legislation. If dust and/or aggressive vapours are present in the room in which it is to be installed, the appliance must operate independently of the air inside the room.

Installation location

Observe the regulations in force, when deciding where to install the device.

Install the appliance in a PERFECTLY VERTICAL POSITION.

The device must not be installed near heat sources. Do not install the device in environments where temperatures may reach 0°C

For installation inside furniture, consider that the maximum temperature of the device jacket is lower than 85°C and distances required for maintenance must be respected.

Gas connection

The appliance was designed to use gases belonging to the categories as shown in the following table.

COUNTRY	MODEL	CATEGORIES
South African	FAST EVO ONT B 11 FAST EVO ONT B 14 FAST EVO ONT B 16	LPG

Make sure, using the labels on the packaging and the data plate on the appliance itself, that the appliance is in the correct country and that the gas category for which the appliance was designed corresponds to one of the categories available in the country where it will be used. The gas supply piping must be created and measured out in compliance with specific legal requirements and in accordance with the maximum power of the appliance; you should also make sure that the shut-off valve is the right size and that it is connected correctly.

Before carrying out the installation, it is recommended that the fuel pipes are cleaned thoroughly in order to remove any residues which could prevent the appliance from operating correctly.

Check that the supplied gas corresponds to the type of gas for which the appliance was designed (see the data plate located on the appliance itself).

It is also important to check that the pressure of the gas (methane or LPG) you will be using to feed the appliance is suitable, because if it is insufficient the power of the generator may be reduced, causing inconvenience for the user.

Water connection

The illustration shows the connections for the water and gas attachments of the appliance.

Check that the maximum water mains pressure does not exceed 10 bar; if it does, a pressure reducing valve must be installed.

Ensure that the minimum pressure is not lower than 2,2 mbar.

View of the hydraulic Connections

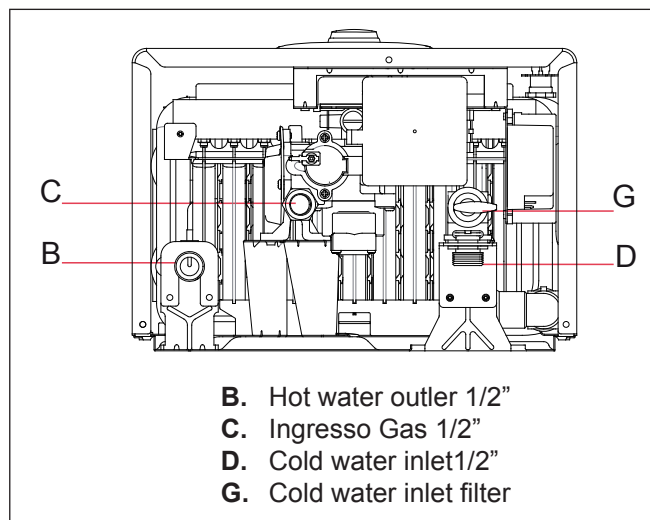

The device is equipped with a filter “G”, located on the cold water entrance. Periodically clean the hydraulic system, if dirt is present.

IMPORTANT!!

Do not activate the device without the filter.

IMPORTANT!

If the unit is installed in areas with the presence of **hard water (> 200 mg / l)** is necessary to install a water softener to reduce the precipitation of limestone in the heat exchanger.

The warranty does not cover damage caused by the limestone.

Connecting to solar installation

When connecting the unit with a solar installation is necessary to verify that incoming water does not exceed 60°C. If it does not provide for the installation of a thermostatic mixing valve.

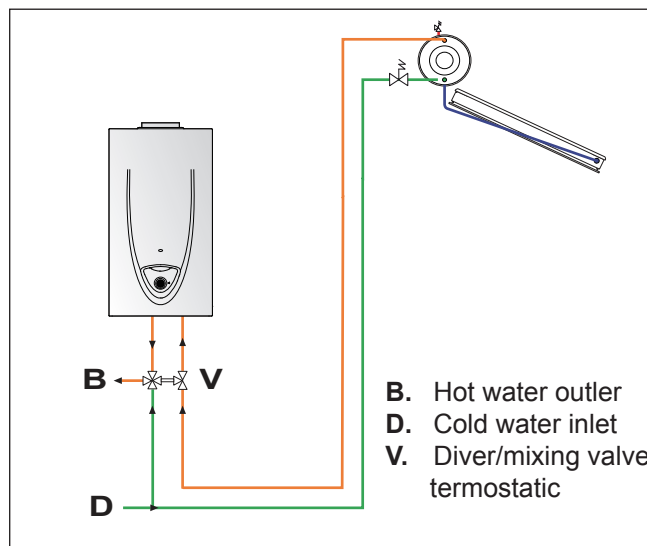

Connection of flue gas discharge ducts

The appliance must be connected to a flue gas discharge system that complies with the regulation in force and instructions provided by the manufacturer.

When type B installation is used, the room in which the appliance is installed must be ventilated using a suitable air inlet which complies with current legislation.

When installing an exhaust system, take care of the seals to prevent any flue gas leaking into the air circuit.



WARNING!!

Never tamper with or decommission the flue gas sensor. This could affect the proper operation of the appliance.

Poor draught conditions could cause exhaust gas backflow into the installation room.

Hazard of carbon monoxide intoxication.

installation

Electrical diagram

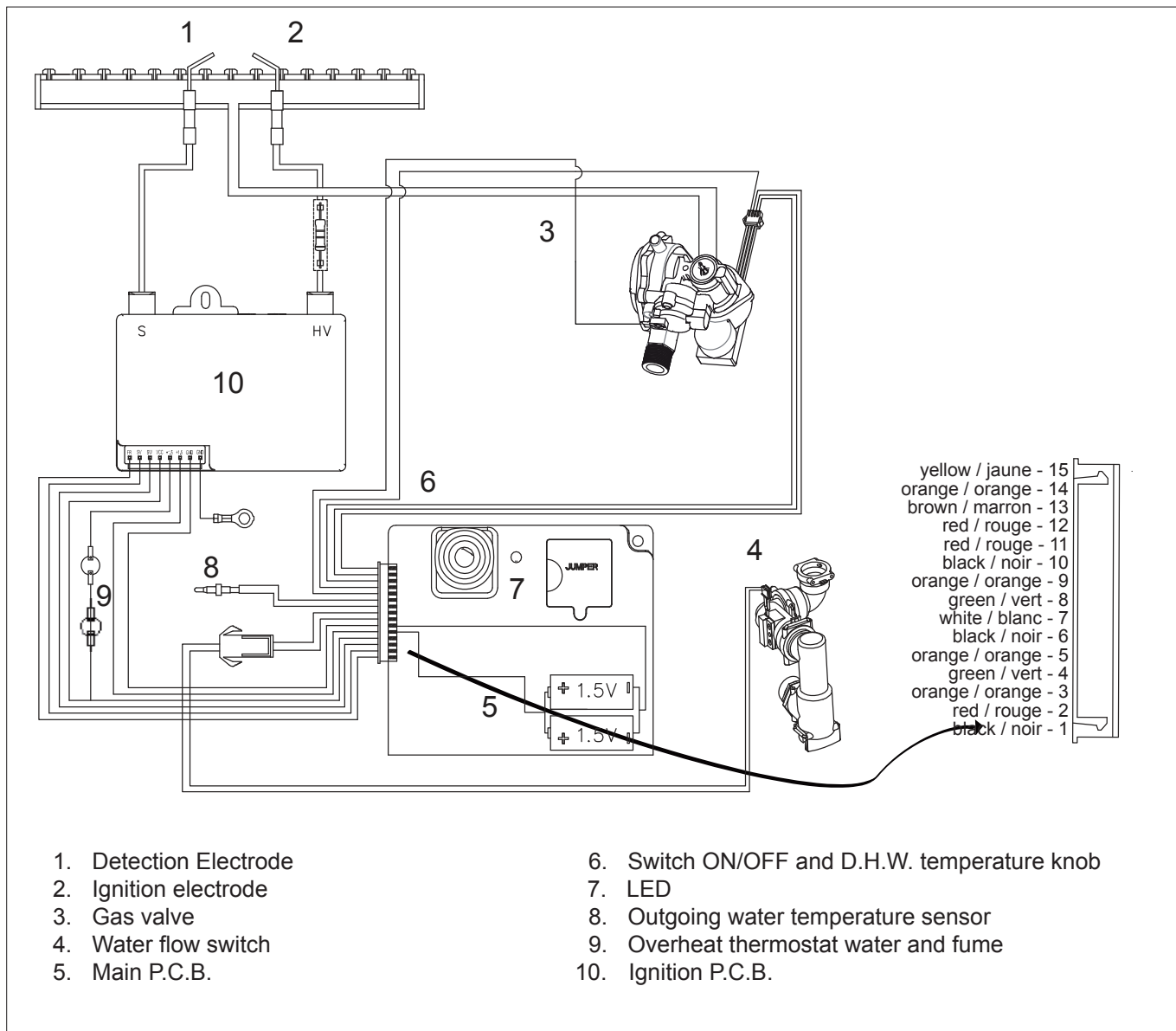

Microswitch

Microswitchs position, see table below.

	MOD.	GAS	Microswitch number							
			1	2	3	4	5	6	7	8
FAST EVO ONT	11 L	G20	ON Test Mode	ON Maximum power adjustment	ON Soft light adjustment	OFF	ON	OFF	OFF	ON
		G30						OFF	ON	OFF
		G31						OFF	ON	ON
	14 L	G20	OFF Factory setting	OFF Minimum power adjustment	OFF Factory setting	ON	OFF	OFF	ON	OFF
		G30						OFF	ON	ON
		G31						OFF	OFF	ON
	16 L	G20	OFF Factory setting	OFF Minimum power adjustment	OFF Factory setting	ON	ON	OFF	OFF	ON
		G30						OFF	ON	OFF
		G31						OFF	ON	ON

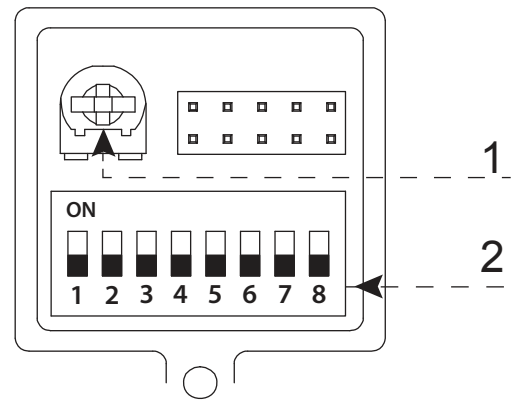
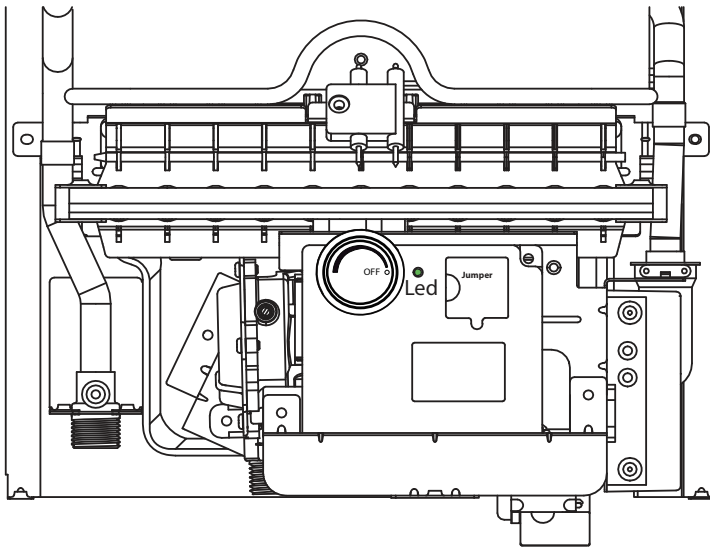

1. Adjusting screw maximum / minimum and Soft ignition power
2. Microswitch

commissioning

Initial procedures

To guarantee safety and the correct operation of the appliance, the appliance must be prepared for operation by a qualified technician who possesses the skills which are required by law.

It's necessary check the gas adjustments when you start the appliance for the first time.

Electricity supply

- Insert the batteries into the relevant compartment correctly based on their polarities.

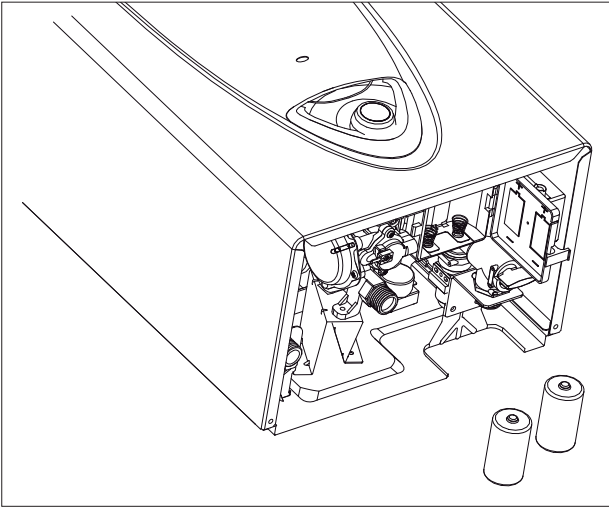

Filling the hydraulic circuit

Proceed in the following manner:

- **Gradually** open the valve located on the cold inlet;
- open a D.H.W. tap.

 **WARNING!!**

DO NOT USE THE APPLIANCE WITHOUT WATER.

Gas supply

Proceed in the following manner:

- Make sure that the main gas supply uses the same type of gas as indicated on the appliance data plate;
- Open all doors and windows;
- Make sure there are no sparks or naked flames in the room;
- Make sure that the system does not leak fuel using a cut-off valve inside the appliance itself which should be closed and then opened while the gas valve is disabled. The meter must not show any signs of gas being used for 10 minutes.

First ignition

The first start-up must be carried out by a qualified technician.

Make sure that:

- The gas valve is closed;
- the exhaust duct for combustion products should be suitable and free from any obstructions;
- Any necessary ventilation inlets in the room should be open (type B installation).

Turn the knob between the positions of minimum and maximum.

Start the appliance by opening a D.H.W. tap.

 **WARNING!!**

Water with a temperature higher than 50°C can cause serious burns.

Always verify water temperature before use.

 **WARNING!!**

DO NOT USE THE APPLIANCE WITHOUT WATER.

Checking the gas settings

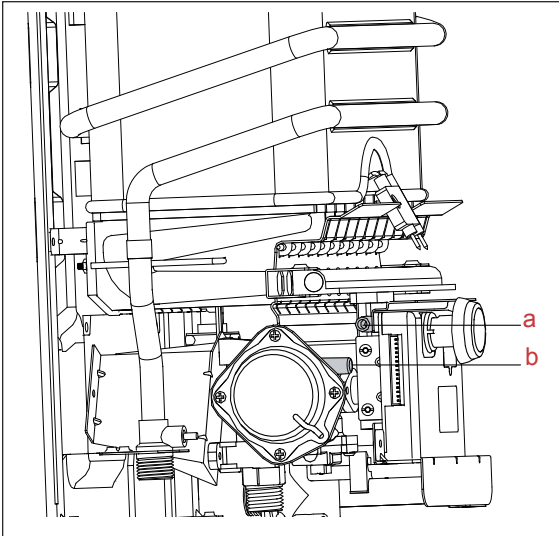

Supply pressure check

1. Close the gas valve.
2. Loosen screw "b" and insert the pressure gauge connection pipe into the pipe tap.
3. Open the gas valve.
4. Switch the appliance ON by opening a DHW tap. The supply pressure should correspond to the value established in relation to the type of gas for which the appliance is designed.
5. Switch the appliance OFF by closing the DHW tap.



WARNING!!

Should the power pressure not correspond to what indicated on the Gas Summary Table, DO NOT ACTIVATE THE DEVICE.

6. Close the gas valve.
7. When the check is over, tighten screw "b" and make sure it is securely in place.
8. Open the gas valve and check the tightness of the screw.

Checking the maximum and minimum pressure (see the Gas setting table)

1. Close the gas valve.
2. Loosen screw "a" and insert the manometer connection pipe into the pipe tap.
3. Open the gas valve.
4. Remove the batteries.
5. Turn microswitch 1 to ON position and re-place the batteries. Open one hot water tap. (Test Mode ON - Flashing orange LED).
6. Turn microswitch 2 to position ON (Appliance forced to maximum power).
7. Adjust maximum burner pressure using the orange screw.
8. Turn microswitch 2 to OFF position (Appliance forced to minimum power).

9. Adjust minimum burner pressure using the orange screw.
10. At the end turn microswitch 1 to OFF position again (test mode OFF). The LED is still orange - all adjustments have been stored. Close the hot water tap.
11. When the check is over, close the gas valve and tighten screw "a", make sure it is securely in place. Open the gas valve and check the tightness of the screw.

WARNING: Every time microswitch 1 is turned to ON, you need to set both maximum and minimum power.

Checking slow ignition power (see the Gas setting table)

1. Close the gas valve
2. Loosen screw "a" and insert the manometer connection pipe into the pipe tap.
3. Open the gas valve
4. Remove the batteries
5. Turn microswitch 1 to ON position and re-place the batteries. Open one hot water tap. (Test Mode ON - Flashing orange LED)
6. Turn microswitch 3 to ON position (Appliance forced to the ignition power).
7. Adjust the slow ignition using the orange screw
8. At the end turn microswitch 3 to OFF position
9. Turn microswitch 1 to OFF position (test mode OFF). The LED is still orange - all adjustments have been stored. Close the hot water tap.
10. When the check is over, close the gas valve and tighten screw "a", make sure it is securely in place. Open the gas valve and check the tightness of the screw.

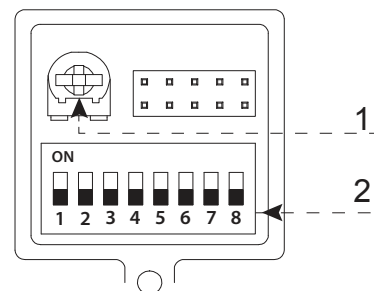

1. Adjusting screw maximum / minimum and Soft ignition power
2. Microswitch

WARNING

The settings of the maximum/minimum pressure and the check of slow ignition must be made separately, according to the instructions and completing the procedure.

commissioning

Gas setting table

		FAST EVO ONT B 11			FAST EVO ONT B 14			FAST EVO ONT B 16		
		G20	G30	G31	G20	G30	G31	G20	G30	G31
lower Wobbe index (15°C, 1013 mbar)	MJ/m ³	45.67	80.58	70.69	45.67	80.58	70.69	45.67	80.58	70.69
Gas inlet pressure	mbar	20	28/30	37	20	28/30	37	20	28/30	37
Gas Burner Pressure- max	mbar	15.0	24.3	32.3	14.0	26,4	34.7	11.1	21.21	28.5
Gas Burner Pressure- min	mbar	3.0	4.5	6.7	2.2	3.5	5.0	1.4	2.42	3.0
Slow ignition pressur	mbar	4.0	5.5	8.3	2.71	4.1	6.0	1.9	2.7	3.6
Main Burner jets	nr.	11			13			14		
Ø burner jets	mm	1.15	0.75	0.75	1.2	0.8	0.8	1.3	0.8	0.8
Max/min consumption (15°C, 1013 mbar) (G.N.= m3/h) (GPL = Kg/h)	MAX	2.28	1.70	1.67	2.86	2.13	2.10	3.28	2.45	2.41

Appliance shut-off conditions

The appliance is protected from malfunctions by means of internal checks performed by the electronic P.C.B., which stops the appliance from operating if necessary. Switch off the appliance. Shut off the gas valve, remove the batteries and contact a qualified technician.

The red LED shows the error codes.

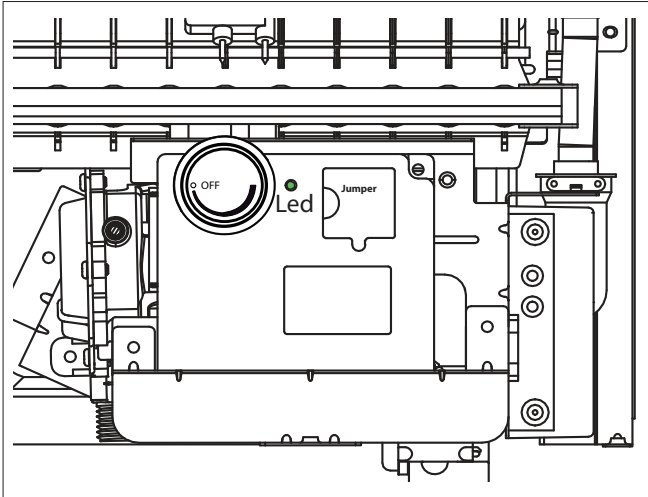

! WARNING!!

Never tamper with or decommission the flue gas sensor. This could affect the proper operation of the appliance.
 Poor draught conditions could cause exhaust gas backflow into the installation room.
 Hazard of carbon monoxide intoxication.

! WARNING!!

Water with a temperature higher than 50° cause serious burns.
 Always verify water temperature before use.

! WARNING!!

DO NOT USE THE APPLIANCE WITHOUT WATER.

Table summarising error

Red ● L.E.D.	Description	Checks to make
Fixed	Battery exhausted	Replace battery
Single flash	The appliance does not turn on	1. Check that the water flow sensor is properly connected 2. Check/Replace the battery
Double flash	No flame detected	1. Check the gas cock. 2. Check the position of the detection electrode
Three flashes	Gas valve defective	Check if the gas diaphragm is not obstructed or locked
Four flashes	Overheat	1. Check for a possible obstruction of the flue 2. Check the water pressure (too low)
Five flashes	Temperature probe defective	1. Check the cable of the temperature probe 2. Check the water pressure (too low)

Temporary Shut-Off due to defective flue gas discharge

This device causes the appliance to shut down in the event of an anomaly in the flue gas discharge.

The appliance shutdown is temporary.

After 12 minutes, the appliance begins the ignition procedure; if normal conditions have been restored, the appliance operates as normal. If not, it shuts down and the cycle is repeated.

WARNING

In the event of a malfunction or if repeated intervention is required:

- switch the appliance off,
- close the gas valve,
- remove the batteries,
- contact the Technical Assistance Service or a qualified technician in order to repair the flue gas discharge fault once the cause of the malfunction is detected.

Whenever maintenance work is performed on the device, use original spare parts only and follow the relative instructions carefully.

maintenance

Instructions for opening the casing and performing an internal inspection

Before performing any work on the appliance, remove the batteries and close the gas valve.

To access the inside of the appliance, you need to:

- Remove the knob **19**
- Remove the three screws **D**
- Fit the casing to the frame using the hooks **E**

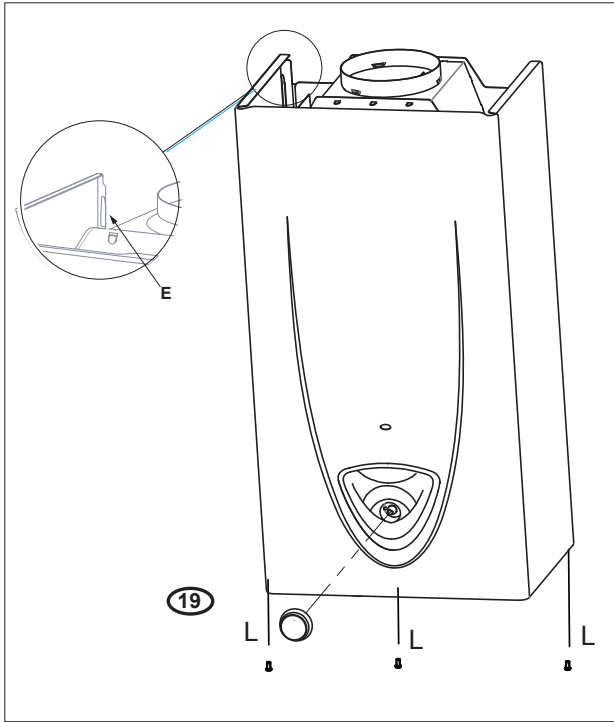

Maintenance is an essential part of the safe and efficient operation of the appliance and ensures its durability. It should be performed according to the instructions given in current legislation.

Before beginning maintenance work:

- Remove the batteries
- Close the gas valve and the domestic hot water system valve.

After the work has been completed the initial settings will be restored.

General comments

It is recommended that the following inspections be carried out on the appliance at least once a year:

1. Visually check the overall condition of the appliance.
2. Check the seals in the water part and, if necessary, replace the gaskets and restore the seal to perfect working order.
3. Check the seals in the gas part and, if necessary, replace the gaskets and restore the seal to perfect working order.
4. Visually check the combustion and, if necessary, disassemble and clean the burner.
5. Following the inspection detailed in point "3", disassemble and clean the combustion chamber, if necessary.
6. Following the inspection detailed in point "4", disassemble and clean the burner and injector, if necessary. Remove oxide from the detection electrode using an emery cloth.
7. Cleaning the primary heat exchanger
8. Make sure the following safety devices are operating correctly:
 - temperature limit safety device.
 - flue gas safety
9. Make sure that the following gas part safety devices are operating correctly:
 - absence of gas or flame safety device (ionisation).
10. Check the efficiency of the domestic hot water production process (test the flow rate and temperature).
11. Cleaning the filter in cold water inlet.
WARNING! THE APPLIANCE MUST NOT BE PUT IN FUNCTION WITHOUT FILTER.
12. Perform a general inspection of the appliance operation.

WARNING!!

Never tamper with or decommission the flue gas sensor. This could affect the proper operation of the appliance.

Poor draught conditions could cause exhaust gas backflow into the installation room.

Hazard of carbon monoxide intoxication.

Operational test

After having carried out the maintenance operations, fill the appliance and the water circuit.

- Begin operating the boiler.
- Check the settings and make sure all the command, adjustment and monitoring parts are working correctly.
- Check the seal and that the system for the expulsion of fumes/suction of comburent air is operating correctly.

Draining procedures

The system must be drained using the following procedure:

- Remove the batteries,
- Shut off the water mains inlet valve,
- Open the hot and cold water taps.

WARNING

Before handling, empty all components which may contain hot water, performing bleeding where necessary. Descale the components in accordance with the instructions provided on the safety data leaflet supplied with the product used, make sure the room is well ventilated, wear protective clothing, avoid mixing different products, and protect the appliance and surrounding objects.

Seal all openings used to take a gas pressure reading or to make any gas adjustments.

Make sure that the nozzle is compatible with the supplied gas.

If a smell of burning is detected or smoke is seen leaking from the appliance, or there is a smell of gas, remove the batteries, shut off the gas valve, open the windows and call for technical assistance.

Information for the user

Inform the user on how to operate the appliance.

In particular, provide the user with the instruction manuals and inform him/her that these must be stored with the appliance.

Moreover, make sure the user is aware of the following:

- How to set the temperature and adjustment devices for using the appliance correctly and in a more cost-efficient way.
- The system must be serviced regularly in compliance with legislation.
- The settings relating to the supply of combustion air and combustion gas must not in any event be modified.

Ariston Thermo SpA

Viale A. Merloni, 45
60044 Fabriano (AN)

www.aristonthermo.it
info.it@aristonthermo.com

2nd of January 2021

To Whom It May Concern,

RE: WARRANTY PERIODS

This letter serves to confirm the warranty periods for the following products:

Type	Description	Warranty Period
ESWH	Trendline Highline Class B Compact Andris Lux	5 years on cylinder 1 year on electrical components 1 year on gasket and flange lid 2 years on valves
EIWH	Aures Slim Aures Slim Multi	1 year on heating element 2 years on tank, product and accessories
GIWH	Fast Evo Fast R	2 years on product
SWH	Solarline Thermo DR	5 years on cylinder 1 year on electrical components 1 year on gasket and flange lid 2 years on valves 5 years on solar collector, excluding glass

The warranty period will commence from the date of purchase or installation, failure to provide proof of this will result in the date of manufacture being used as indicated on the serial label:

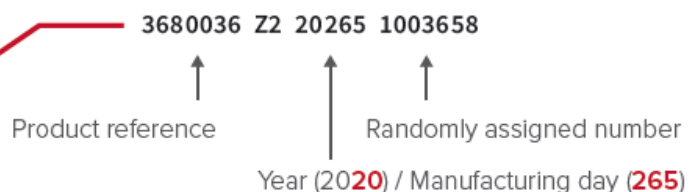
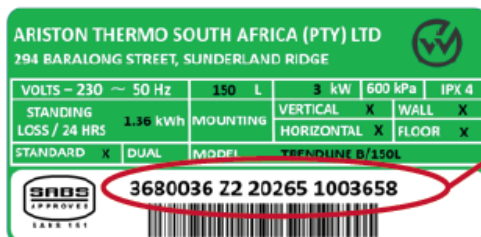

▶ Please quote the full 21 character number when reporting a service call

Whilst the product or spare parts are still under warranty, Ariston Thermo SA must be contacted for prompt assistance.

Under no circumstances must the unit be removed from the installation. Ariston Thermo SA reserves the right to require proof that the product installation complies before a service call would be registered.

Ariston Thermo South Africa (Pty) Ltd

294 Barolong St., Icon Park, Sunderland Ridge, Centurion, 0157, South Africa. P.O Box 8446, Centurion 0046

T: +27 (0)87 943 7471 F: +27 (0)87 941 7403 E: info@heattech.co.za

www.heattech.co.za / www.ariston.com

Reg No 2010/022406/07



WARRANTY PROCEDURE

Herewith a kind reminder to our valued customers of the Ariston/Heat Tech Warranty Procedure.

- 1.) Warranty periods on Ariston/Heat Tech Geysers:
 - 5 Years on Inner Cylinder
 - 1 Year on Electrical (Element & Thermostat)
 - 2 Years on Safety Valve & Drain Cock
- 2.) Please always urge your customers to utilize qualified plumbers to do installations of Ariston/Heat Tech geysers.
- 3.) **Please always inform your customers when selling Ariston/Heat Tech geysers, that they should never remove the geyser from the original installation during the warranty period, as this will automatically void the warranty.** All geysers must remain in position and untampered with, allowing our service agent to inspect the reported problem.
- 4.) **Please never accept the return of a geyser to your store, and please never offer a replacement geyser from the store to the customer.** This would effectively mean that the geyser has been removed from the installation, which voids the warranty, and Ariston/Heat Tech will then not be able to assist either the store, nor the end user customer.
- 5.) Kindly educate your customers to **follow the below warranty procedure** to avoid disputes or misunderstandings in future :
 - a.) After the customer has determined that the problem with the water heater is related to, AND covered under the warranty conditions, the customer has to report the problem DIRECTLY to our Service Centre. All geysers must remain in position and untampered with, allowing our service agent the opportunity to inspect the reported problem.
 - b.) When reporting the problem to our Service Call Centre, the customer or end user will be required to provide the following information:
 - Geyser Serial Number
 - DOM (Date of Manufacturing)
 - Geyser Size
 - Proof of purchase/installation date
 - End Users Name, Surname, Contact Telephone Number(s) & e-mail address
 - Installation Address
 - Merchant Name (i.e. where geyser was purchased)
 - The Problem with the geyser
 - In some cases the end user customer *may* be requested to provide indicative photo(s) of the installation.

c.) Customers can contact the Ariston/Heat Tech After Sales Service Department at:

- Contact Number 1: 079 921 0118
- Contact Number 2: 087 943 7470
- e-mail : service@heattech.co.za
- Operating Hours: Mon to Fri 07:30 to 18:00
- Sat to Sun 07:30 to 15:00

d.) It may be preferable for yourself and/or end user to rather send an e-mail to service@heattech.co.za whereby providing the required information, saving time, and thereby having a record of the reported incident.

e.) The customer will be given a reference number for the incident reported.

f.) Ariston/Heat Tech Service Agent will then contact the end user customer to make the necessary further arrangements.

May we please ask that you distribute to, and advise your relevant staff accordingly.

Kind regards ,

INSTALLATION AND WARRANTY INSTRUCTIONS

IT IS THE RESPONSIBILITY OF THE INSTALLER TO INFORM THE END USER OF THE INSTALLATION, MAINTENANCE & REPAIR REQUIREMENTS FOR THIS WATER HEATER IN ACCORDANCE WITH SANS 10254 AND THE MANUFACTURERS REQUIREMENTS.

INSTALLATION INSTRUCTIONS - PLUMBING TO BE INSTALLED BY A QUALIFIED PLUMBER AND TO COMPLY WITH SANS 10254 & 10252-1 INSTALLER TO ISSUE A PLUMBING CERTIFICATE OF COMPLIANCE

This water heater must be fitted with the supplied TP VALVE before installation. Always fit this water heater with a PRESSURE CONTROL VALVE and EXPANSION CONTROL VALVE (which may be combined in one unit) not exceeding the kPa rating of the water heater as stated on the serial label. TP VALVE and EXPANSION VALVE overflow pipes must be led separately to the outside of the building in a continuous downward direction, in a frost free ambient with the outlets being left open to the atmosphere, and in case of the TP VALVE must be copper. The EXPANSION VALVE is designed to drip under normal operating conditions and must never be plugged.

1. Flush the cold water supply line prior to connecting.
2. Check that the control valve is free from dirt.
3. Ensure all piping and water heater brackets are securely fixed.
4. After connecting the installation, open one or more hot water taps and open the cold water to dispel air from the system.
5. Close all hot taps to bring water heater under pressure.
6. Check all plumbing connections for leaks.
7. Installation diagrams must be complied with in all respects.
8. The installation of a drip tray is required where water leaking from the water heater or connections could cause consequential damage.

INSTALLATION INSTRUCTIONS - ELECTRICAL ELECTRICAL WORK TO BE CARRIED OUT BY A QUALIFIED ELECTRICIAN AND TO COMPLY WITH SANS 10142-1 WARNING: THIS APPLIANCE MUST BE EARTHED & BONDED

1. Heat resisting round 2.5mm² (minimum) 3 core stranded cable should be used to connect the electrical supply.
2. A double pole isolator switch to be installed within 1m of the water heater - correctly rated for the element size.
3. Circuit breaker on distribution board to be correctly rated for the element size.
4. Turn off the circuit breaker on the distribution board as well as the isolator at the water heater.
5. Remove the electrical access panel.
6. Cut away tips of old electrical wire, stripping away the insulation.
7. Connect and tightly secure electrical connection to the thermostat / terminal block. Ensuring thermostat is tightly inserted into the element.
8. Replace electrical access panel.
9. Ensure the water heater is full of water before switching on electricity, even for testing purposes.
10. Heating element will burn out if turned on without water.

INSTALLATION INSTRUCTIONS - WALL MOUNTING

1. Remove brackets from the floor mounting position and bolt to side of the unit in the wall mounting position.
2. Bolt unit to the wall using suitable rated fixation bolts.

NOTE: 200L & 250L UNIT MAY NOT BE WALL MOUNTED

MAINTENANCE INSTRUCTIONS

SWITCH OFF ELECTRICAL SUPPLY BEFORE ATTEMPTING ANY MAINTENANCE OR REPAIRS ON THE WATER HEATER

REPLACEMENT OF THERMOSTAT

1. Disconnect wiring, remove thermostat by pulling it out of its pocket.
2. Fit new thermostat, ensuring the stem of the thermostat is not bent or damaged in any way. On electronic models, ensure that the metallic thermostat bulb is inserted before the wired probe.
3. Reconnect wiring to thermostat ensuring connections are clean, tight and secure.
4. Set thermostat to 60°C or as required by user.

REPLACEMENT OF ELEMENT

1. Drain water from the water heater.
2. Remove thermostat as above and remove flange lid from cylinder.
3. Remove old element and gasket from flange lid.
4. Fit new element and gasket to flange lid.
5. Refit flange lid, and replace thermostat as above.

REPLACEMENT OF ANODE

1. The magnesium anode installed in a vitreous enamel lined steel water heater will slowly dissipate whilst protecting the cylinder.
2. The life of the cylinder may be extended by replacing the anode.
3. Inspect the anode yearly, and if required, replace the anode.
4. Replacement of the anode should be carried out at minimum 2 year intervals, during the warranty period, to ensure protection of the steel cylinder.
5. The life expectancy of the anode would be dependent on the water quality in the area, which the water authority can advise on.
6. A guideline below (as reference only):

TOTAL DISSOLVED SOLIDS PPM	RECOMMENDED REPLACEMENT
0 - 400	3 Years
400 - 600	2 Years
Over 600	1 Year

Fitment of an aluminium anode is recommended for harsh water conditions.

7. When water is supplied from a borehole or well, anodes should be replaced at least once a year.
8. Replace anode as follows:
 - (a) Drain water heater.
 - (b) Remove anode cover and unscrew anode from cylinder.
 - (c) Fit new anode and replace anode cover.

THE ANODE IS A MAINTAINABLE COMPONENT

ALL PIPE WORK AND COMPONENTS CONNECTED TO THE INLET, OUTLET AND T&P VALVE SHOULD BE THERMALLY INSULATED FOR 2 METERS. THE THERMAL INSULATION SHALL COMPLY WITH THE REQUIREMENTS OF SANS 10252-1, SANS 10254, SANS 10400-XA AND SANS 204.

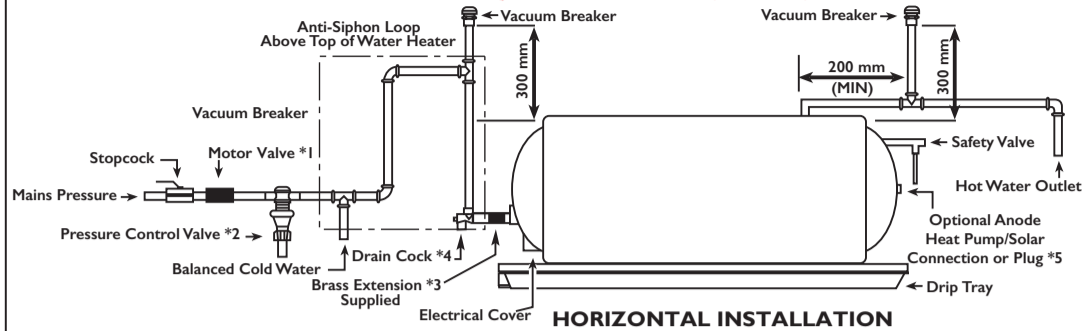

THIS WATER HEATER IS FITTED WITH A MAGNESIUM ANODE THAT REQUIRES PERIODIC REPLACEMENT

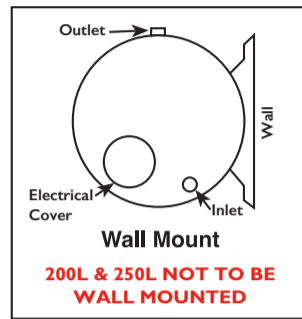

200L & 250L NOT TO BE WALL MOUNTED

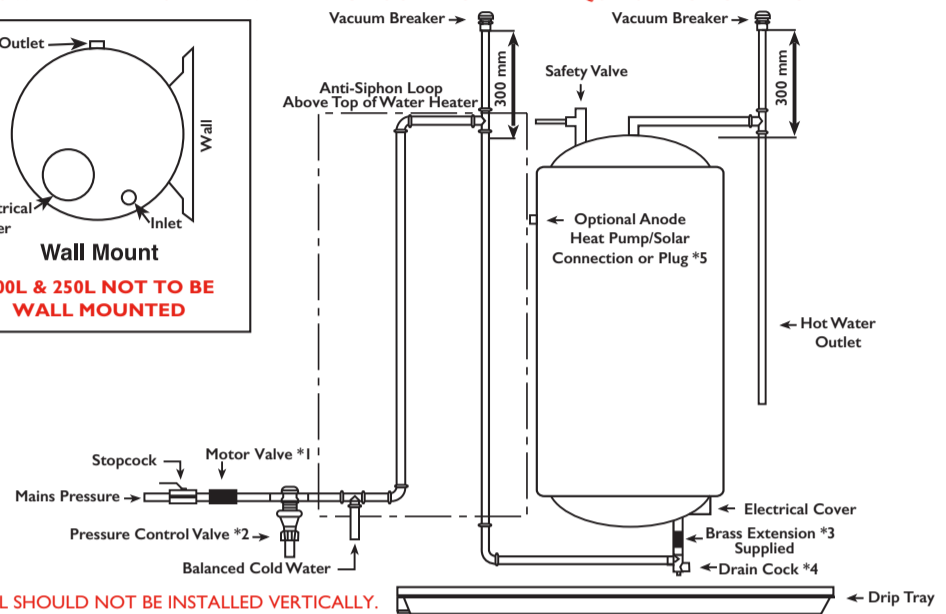

50L & 250L SHOULD NOT BE INSTALLED VERTICALLY.

- *1 Optional extra for certain models only
- *2 Refer to the serial label for the correct pressure rating of the water heater.
- *3 Supplied on certain models only.
- *4 Solar or heat pump compatible when used in conjunction with a dual drain cock.
- *5 When not using the additional socket for solar or heat pump - ENSURE THAT THE SOCKET IS PLUGGED.

The following minimum installation clearance must be allowed for on the electrical side of the water heater in the event of having to remove the element, thermostat or the anodes and 500mm on the opposite side.

50L - 500mm	100L - 700mm	150L - 950mm	200L - 1500mm	250L - 1500mm
-------------	--------------	--------------	---------------	---------------

WARRANTY *T & C Apply

This water heater is warranted against faulty materials and/or workmanship not withstanding anything to the contrary contained herein. The company will repair or at its own discretion, replace a defective unit or parts inclusive of labour costs during the warranty period. The repaired or replaced part, or water heater, warranty will still be calculated from original date of manufacture, not from the repaired or replacement date.

The period of warranty is calculated from the date of manufacturing as indicated on the serial plate. This is the only warranty given and it expressly excludes all other warranties, expressed or implied by law. The warranty expressly covers the water heater only and does NOT cover any other part or parts of the installation which may, because of the failure or defect of the water heater become damaged in any way whatsoever and under no circumstances shall the manufacturer be liable for any direct, indirect or consequential loss suffered by the consumer and/or third party.

The warranty is subjected to the following:

- (a) The water heater is installed in accordance with SANS 10142-1: (Electrical) and SANS 10254 & 10252-1 (Plumbing) and in accordance with any other applicable national and local regulations.
- (b) The water heater is installed according to the manufacturers installation requirements.
- (c) The water heater is maintained and serviced yearly.
- (d) The anode is inspected yearly and replaced at least every second year for municipal water supplies.
- (e) The serial plate is not damaged or tampered with in any way.
- (f) The water heater is subjected to normal use with municipal water supply and proper installation by qualified personnel.
- (g) This warranty will exclude any failure due to hard water conditions.
- (h) Elements burnt out due to no water, or element and thermostat terminals burnt / melted are excluded from this warranty.
- (i) The above warranty is subject to only genuine replacement parts being used whilst the inner cylinder is still under warranty.
- (j) The above warranty shall however be completely invalidated if any repairs are effected by the customer or others on his behalf in an attempt, to remedy the alleged fault.
- (k) Under no circumstances must the unit be removed from the installation.
- (l) Sufficient access to the water heater for either repairs or replacement is the responsibility of the end user. The manufacturer will not make good or reassemble any ceilings or cupboards.
- (m) As per SANS 10254, no one-way valve or stop cock allowed between the water heater and expansion relief valve.



HEATTECH

Manufactured by: HEAT TECH GEYSERS (PTY) LTD
294 Barolong Street, Sunderland Ridge
Tel: 087 943 7471

Email: info@heattech.co.za
Web: www.heattech.co.za

WARRANTY PERIODS *T & C apply

Cylinder	5 Years
Electrical Components	1 Year
Gaskets	1 Year
Drain Cock and T&P Valve	2 Years
Anode (consumable, service required)	None

After-Sales Service: 087 943 7470 / service@heattech.co.za