

SINGLE IMPELLER CENTRIFUGAL PUMPS

CAWC075 • CAWC110



APPLICATION

Cascade single impeller pumps suitable to cover any small, medium or large capacity request. For domestic, agricultural and industrial purposes. With automatic water distribution through small and medium-sized tanks, for sprinkler and flood irrigation in gardening and agriculture. Suitable for use clean water, or non-aggressive liquids only, without sand or other solid impurities. Suitable for industrial use and urban water supply pressure boosting for high rise buildings and garden irrigation.



OPERATING CONDITIONS

- Suction lift up to 6 - 8 m with foot valve
- Max. operating pressure: 8 bar
- Max. ambient temperature: + 40°C
- Liquid temperature up to + 60°C

MOTOR

- Insulation Class B
- Protection IP44
- Single-phase power supply with capacitor permanently activated
- Internal thermal protector
- Speed of rotation: 2850 rpm
- Continuous duty: S1
- Electrophoresis anti-rust treatment

MATERIALS

- Pump body - Cast Iron
- Impeller - Brass
- Motor shaft - AISI1045
- Mechanical seal - NBR/Graphite/Ceramic

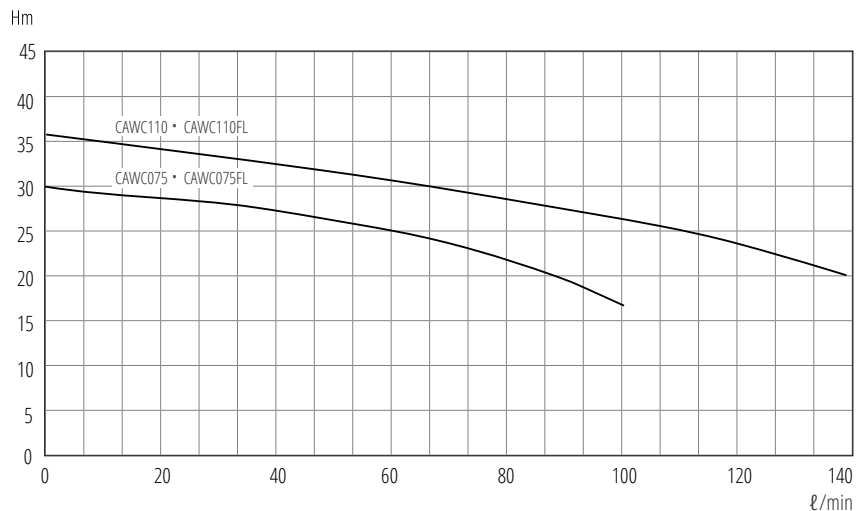

MODEL	NOMINAL POWER		uF	AMPERE	Q l/min	Flow Rate (l/min)													
	HP	KW				0	20	40	60	80	90	100	120	140					
				Single-phase	m ³ /h	0	1.2	2.4	3.6	4.8	5.4	6.0	7.2	8.4					
CAWC075	1	0.75	20	5.0	H (m)	30	29	27.5	26	23	21	17	-	-					
CAWC110	1.5	1.1	30	7.0		37	35	33	31	29	28	26.5	24	22.8					

CENTRIFUGAL PUMP WITH FLOW CONTROL

CAWC075FL • CAWC110FL



TYPE	L1	W1	H1	L2	W2	H2	DN1	DN2	N.W (kg)	PACKAGE DIMENSION (mm)		
										L	W	H
CAWC075	303	190	243	42.5	167	96	1"	1"	13	320	220	270
CAWC110	258	215	279	55	180	110	1"	1"	21	365	235	300

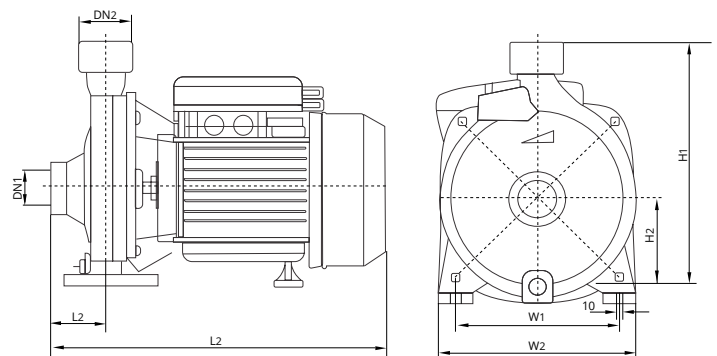

NRCS HOUSEHOLD APPLIANCES\ELECTRONIC LETTER OF AUTHORITY

APPLICANT NAME :	HINTERLAND SA		
TRADING NAME :	AGRINET		
POSTAL ADDRESS :	PRIVATE BAG X165 CENTURION 0046	PHYSICAL ADDRESS :	111 STERLING STREET KOSMOSDAL SAMAND 0157
CONTACT PERSON/S :	FELICIA MNATA		
TEL NO :	012 6572000		
FAX NO :	086 529 4479		
E-MAIL :	morney@agrinet.co.za		

CUSTOMS IMPORTER CODE :	CHECKED
VAT REGISTRATION NO :	CHECKED
COMPANY REGISTRATION NO :	CHECKED

TARIFF HEADING:	8413.81	REBATE CODE:	
DESCRIPTION	BRAND	COUNTRY OF ORIGIN	APPLICABLE STANDARD
CASCADE PUMPS	CASCADE	CHINA	SANS IEC 60335-2-41

MODEL#
CAVFF8-40

ACCEPTED VARIATIONS			
VFF4-60	CAVFF2-60	CAWCM2150FL	
CAWCM2200FL	CAWC075	CAW075FL	
CAWC110FL	CAWJS075	CAWJS075FL	
CAWJL075FL	CAWV037	CAWV03FL	
where != Blank \$ = Alpha # = Numeric @ = Alphanumeric * = Blank or Alphanumeric			

CERTIFICATE NO :	000000173300/001	EXPIRY DATE:	07 Feb 2025
DATE OF ISSUE :	07 Feb 2022		
AUTHORIZING OFFICER :	Stephina Teffo	AUTHORIZED :	
DATABASE ENTRY NO :	173300		

This certificate is issued subject to the conditions attached overleaf

Head Office

SBS Campus 1 Dr Lategan Road Groenkloof Pretoria

✉ NRCS Private Bag X25, Brooklyn Square 0075

☎ Tel: +27 12 482 8700 • Hotline 0800 214 719 • Fax: +27 86 404 7431

@ Web: www.nrccs.org.za