

# TWIN IMPELLER SELF PRIMING CENTRIFUGAL PUMP 1.5 kW 230 V

CAWCM2200



## APPLICATION

Twin impeller centrifugal water pumps to lift clean water and non-aggressive liquids. The main feature is the two opposite impellers that allow higher lifts than in the single impeller model. The pumps can be used for civil and industrial applications, for water distribution and for irrigation. 100% Copper windings, brass impellers and an IP Rating of 44.



## OPERATING CONDITIONS

- Max. operating pressure: 8 bar
- Max. ambient temperature: + 40°C
- Liquid temperature up to + 60°C

## MOTOR

- Insulation Class B
- Protection IP44
- Single-phase power supply with capacitor permanently activated
- Internal thermal protector
- Speed of rotation: 2850 rpm
- Continuous duty: S1
- Electrophoresis anti-rust treatment

## MATERIALS

- Pump body - Cast Iron
- Impeller - Brass
- Motor shaft - AISI1045
- Mechanical seal - NBR/Graphite/Ceramic

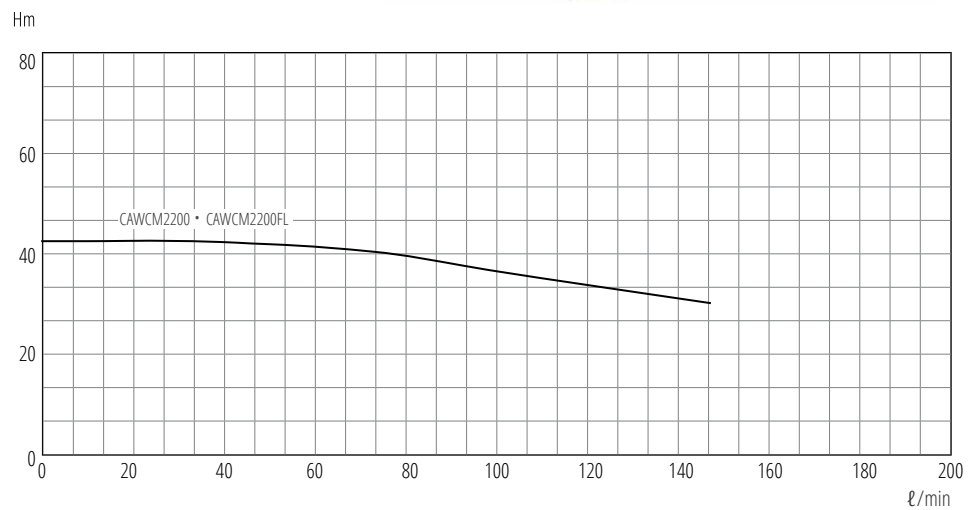

| TYPE      | NOMINAL POWER |     | uF | AMPERE | Q<br>l/min | Flow rate (l/min) |      |    |    |    |    |      |      |      |     |     |     |  |  |  |  |
|-----------|---------------|-----|----|--------|------------|-------------------|------|----|----|----|----|------|------|------|-----|-----|-----|--|--|--|--|
|           | HP            | KW  |    |        |            | 0                 | 20   | 40 | 60 | 80 | 90 | 100  | 110  | 120  | 140 | 160 | 200 |  |  |  |  |
| CAWCM2200 | 3             | 2.2 | 45 | 10     | H (m)      | 43                | 42.5 | 42 | 41 | 40 | 39 | 38.5 | 36.5 | 34.5 | 32  | -   | -   |  |  |  |  |

## SELF PRIMING CENTRIFUGAL PUMP WITH FLOW CONTROL

CAWCM2200FL



| TYPE      | L1  | W1  | H1  | L2  | L3 | DN1  | DN2   | N.W (kg) | PACKAGE DIMENSION (mm) |     |     |
|-----------|-----|-----|-----|-----|----|------|-------|----------|------------------------|-----|-----|
|           |     |     |     |     |    |      |       |          | L                      | W   | H   |
| CAWCM2200 | 415 | 205 | 250 | 100 | 73 | 1.5" | 1.25" | 24       | 425                    | 230 | 265 |

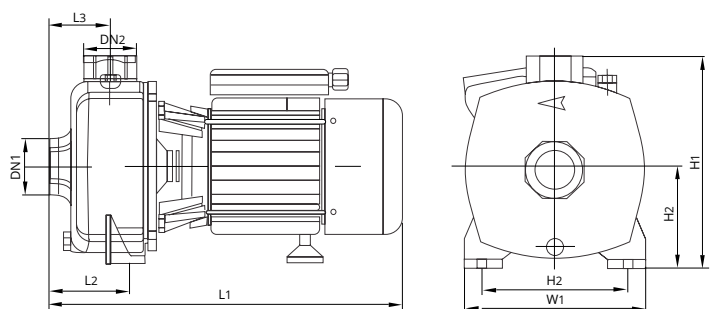

**NRCS HOUSEHOLD APPLIANCES\ELECTRONIC LETTER OF AUTHORITY**

|                           |                                       |                           |  |
|---------------------------|---------------------------------------|---------------------------|--|
| <b>APPLICANT NAME :</b>   | HINTERLAND SA                         |                           |  |
| <b>TRADING NAME :</b>     | AGRINET                               |                           |  |
| <b>POSTAL ADDRESS :</b>   | PRIVATE BAG X165<br>CENTURION<br>0046 | <b>PHYSICAL ADDRESS :</b> | 111 STERLING STREET<br>KOSMOSDAL<br>SAMAND<br>0157 |
| <b>CONTACT PERSON/S :</b> | FELICIA MNATA                         |                           |  |
| <b>TEL NO :</b>           | 012 6572000                           |                           |  |
| <b>FAX NO :</b>           | 086 529 4479                          |                           |  |
| <b>E-MAIL :</b>           | morney@agrinet.co.za                  |                           |  |

|                                  |         |
|----------------------------------|---------|
| <b>CUSTOMS IMPORTER CODE :</b>   | CHECKED |
| <b>VAT REGISTRATION NO :</b>     | CHECKED |
| <b>COMPANY REGISTRATION NO :</b> | CHECKED |

|                        |              |                          |                            |
|------------------------|--------------|--------------------------|----------------------------|
| <b>TARIFF HEADING:</b> | 8413.81      | <b>REBATE CODE:</b>      |                            |
| <b>DESCRIPTION</b>     | <b>BRAND</b> | <b>COUNTRY OF ORIGIN</b> | <b>APPLICABLE STANDARD</b> |
| CASCADE PUMPS          | CASCADE      | CHINA                    | SANS IEC 60335-2-41        |

|               |
|---------------|
| <b>MODEL#</b> |
| CAVFF8-40     |

|  |           |             |  |
|--|-----------|-------------|--|
| <b>ACCEPTED VARIATIONS</b>   |           |             |  |
| VFF4-60  | CAVFF2-60 | CAWCM2150FL |  |
| CAWCM2200FL  | CAWC075   | CAW075FL    |  |
| CAWC110FL  | CAWJS075  | CAWJS075FL  |  |
| CAWJL075FL   | CAWV037   | CAWV03FL    |  |
| where != Blank    \$ = Alpha    # = Numeric    @ = Alphanumeric    * = Blank or Alphanumeric |           |             |  |

|                              |                  |                     |   |
|------------------------------|------------------|---------------------|---|
| <b>CERTIFICATE NO :</b>      | 000000173300/001 | <b>EXPIRY DATE:</b> | 07 Feb 2025   |
| <b>DATE OF ISSUE :</b>       | 07 Feb 2022      | <b>AUTHORIZED :</b> |  |
| <b>AUTHORIZING OFFICER :</b> | Stephina Teffo   |                     |   |
| <b>DATABASE ENTRY NO :</b>   | 173300           |                     |   |

This certificate is issued subject to the conditions attached overleaf

**Head Office**

SBS Campus 1 Dr Lategan Road Groenkloof Pretoria

✉ NRCS Private Bag X25, Brooklyn Square 0075

☎ Tel: +27 12 482 8700 • Hotline 0800 214 719 • Fax: +27 86 404 7431

@ Web: www.nrccs.org.za