

NEXT OUTDOOR EVO

**USER'S MANUAL
INSTALLATION AND SERVICING INSTRUCTIONS**

GAS WATER HEATER

HOT WATER | HEATING | RENEWABLE | AIR CONDITIONING

User's manual

General warnings	3
Safety regulations	4
Remote Control	5
Display	5
Ignition procedure	6
Water temperature adjustment	6
Bath Function	6
Switching off procedure	7
Appliance shut-off conditions	7
Anti-freeze protection	7
Change gas type	7
Maintenance	7

Installation and servicing instructions (Only for qualified technician).....	8
---	----------

Dear Customer,

Thank you for choosing an ARISTON gas water heater.

We guarantee that your instantaneous water heater is a reliable and technically sound product.

This manual provides detailed instructions and recommendations for proper installation, use and maintenance.

Remember to keep this manual in a safe place for future reference i.e. by the gas meter.

Your local ARISTON Servicing Centre is at your complete disposal for all requirements.

FOR YOUR SAFETY

“Important: Read these instructions for use carefully so as to familiarize yourself with the appliance before connecting it to its gas container. Keep these instructions for future reference”.

IF YOU SMELL GAS:

- * Turn off gas supply at bottle
- * Extinguish all naked flames;
- * Do not operate any electrical appliances
- * Ventilate the area
- * Check for leaks as detailed in this manual

If odour persists, contact your dealer or gas supplier immediately

Do not tamper or modify the appliance.

BURN-BACK (FIRE IN BURNER TUBE OR CHAMBER)

In the event of a burn-back, where the flame burns back to the jet, immediately turn the gas supply off at the control valve on the panel. After ensuring the flame is extinguished, wait for 1 minute and re-light the appliance in the normal manner. Should the appliance again burn back, close the control valve and call a service technician. Do not use the appliance again until the service technician has declared that it is safe to do so.

GAS-PRESSURE REGULATOR

This appliance requires an operating pressure of 2,8 kPa at the appliance. A suitable LPG regulator that complies with the requirements of SANS 1237 must be installed.

IMPORTANT INFORMATION FOR THE USER

This appliance may only be installed by a registered SAQCC Gas installer. All registered installers are issued with a card carrying their registration number. Ask to be shown the card before allowing the installation work to commence and make a note of the Installer registration number. Upon completion of the installation, the installer is required to explain the operational details of the appliance together with the safety instructions. You will be asked to sign acceptance of the installation and be provided with a completion certificate. You should only sign for acceptance of the installation when the installation is completed to your satisfaction.

Note that your invoice is required in the event that you wish make a warranty claim.

IMPORTANT INFORMATION FOR THE INSTALLER.

This appliance may only be installed by a gas installer registered with the South African Qualification and Certification Committee (SAQCC). The appliance must be installed in accordance with the requirements of SANS 10087-1 for use with LPG, SANS 827 for use with NG and any fire department regulations and/or local bylaws applicable to the area. If in doubt, check with the relevant authority before undertaking the installation. Upon completion of the installation you are required to fully explain and demonstrate to the user the operational details and safety practices applicable to the appliance and the installation.

This book (user's and installation manual) is an integral and essential component of the product.

Must be kept carefully by you and will always accompany the appliance in the event of its sale to another owner or user and / or transfer to another installation.

Carefully read the instructions and warnings contained in this manual as it contain important information about safe installation, operation and maintenance

This appliance is designed to produce hot water for domestic use.

It should be connected to a distribution network for domestic hot water that must be compatible with its performance and power levels.

The use of the appliance for purposes other than those specified is strictly forbidden. The manufacturer cannot be held responsible for any damage caused by improper, incorrect and unreasonable use of the appliance or by the failure to comply with the instructions given in this manual. Installation, maintenance and all other interventions must be carried out in full conformity with the governing legal regulations and the instructions provided by the manufacturer.

Incorrect installation can harm persons, animals and possessions; the manufacturing company shall not be held responsible for any damage caused as a result.

In the event of a fault and/or malfunction, turn the appliance off, turn off the gas cock and do not attempt to repair it yourself. Contact a qualified professional instead. Before any maintenance or repair work is performed on the appliance, make sure you have disconnected it from the electricity supply by switching the external bipolar switch to the "OFF" position and removing the fuse.

All repairs, which should only be performed using original spare parts, should be carried out by a qualified professional.

Failure to comply with the above instructions could compromise the safety of the appliance and invalidate all liability on the part of the manufacturer

In the event of any maintenance or other structural work in the immediate vicinity of the ducts or flue gas exhaust

devices and their accessories, switch the appliance off by switching the external bipolar switch to the "OFF" position and shutting off the gas control valve.

When the work has been completed, ask a qualified technician to check the efficiency of the ducting and the devices.

If the appliance should be out of use for a prolonged period, it is recommended that the electrical power supply be disconnected and that the external gas cock be closed. If low temperatures are expected, the appliance and system pipe work should be drained in order to prevent frost damage.

When permanently deactivating the appliance, make sure that the operations are carried out by qualified technical professional.

Turn the appliance off and turn the external switch "OFF" to clean the exterior parts of the appliance.

No inflammable items should be left or used in the vicinity of the appliance.

Do not allow children or inexperienced persons to use the appliance without supervision.

The appliance is not to be used by persons (including children) with reduced physical, sensory or mental capabilities, or lack of experience and knowledge, unless they have been given supervision or instruction children being supervised not to play with the appliance.

Disconnection must be incorporated in the fixed wiring in accordance with the wiring rules.

WARNING!!



Water with a temperature higher than 50° cause serious burns.

Always verify water temperature before use..

WARNING!!



The device must be activated only in presence of water in the exchanger.

IMPORTANT!!



If the appliance is installed in a **hard water area (> 200 mg/l)**, a softener should be installed to limit the amount of limescale building up in the heat exchanger.

The guarantee does not cover damage caused by limescale.

Safety regulations

Key to symbols:

Failure to comply with this warning implies the risk of personal injury, in some circumstances even fatal



Failure to comply with this warning implies the risk of damage, in some circumstances even serious, to property, plants or animals.



Do not perform operations which involve opening the appliance.

Electrocution from live components.

Personal injury caused by burns due to overheated components, or wounds caused by sharp edges or protrusions.



Do not perform operations which involve removing the appliance from its installation space .

Electrocution from live components.

Explosions, fires or intoxication caused by gas leaking from disconnected piping.



Flooding caused by water leaking from disconnected piping.



Do not damage the power supply cable.

Electrocution from live uninsulated wires.



Do not leave anything on top of the appliance.

Personal injury caused by an object falling off the appliance as a result of vibrations.



Damage to the appliance or items underneath it caused by the object falling off as a result of vibrations.



Do not climb onto the appliance.

Personal injury caused by the appliance falling.



Damage to the appliance or any objects underneath it caused by the appliance falling away from its installation space.



Do not climb onto chairs, stools, ladders or unstable supports to clean the appliance.

Personal injury caused by falling from a height or cuts (stepladders shutting accidentally).



Do not attempt to clean the appliance without first switching it off and turning the external switch to the OFF position.

Electrocution from live components.



Do not use insecticides, solvents or aggressive detergents to clean the appliance.

Damage to plastic and painted parts.



Do not use the appliance for any use other than normal domestic use.

Damage to the appliance caused by operation overload.



Damage caused to objects treated inappropriately.

Do not allow children or inexperienced individuals to operate the appliance.

Damage to the appliance caused by improper use.



If you detect a smell of burning or smoke coming from the appliance, disconnect it from the electricity supply, turn off the main gas valve, open all windows and call for assistance.

Personal injury caused by burns, smoke inhalation, intoxication.



If there is a strong smell of gas, turn off the main gas valve, open all windows and call for assistance.

Explosions, fires or intoxication.



Do not damage or remove seals on components. Only a qualified technician is authorized to make modifications to the sealed components.

If the supply cord is damaged, it must be replaced by a special cord or assembly available from the manufacturer or its service agent.

This appliance can be used by children aged from 8 years and above and person with reduced physical, sensory or mental capabilities or lack of experience and knowledge if they have been given supervision or instruction concerning use of the appliance in a safe way and understand the hazards involved. Children shall not play with the appliance. Cleaning and user maintenance shall not be made by children without supervision.

WARNING

INSTALLATION, FIRST IGNITION AND MAINTENANCE WORK MUST BE PERFORMED BY QUALIFIED PERSONNEL ONLY, IN ACCORDANCE WITH THE INSTRUCTIONS PROVIDED.

INCORRECT INSTALLATION MAY HARM INDIVIDUALS, ANIMALS OR PROPERTY; THE MANUFACTURER WILL NOT BE HELD RESPONSIBLE FOR ANY DAMAGE CAUSED AS A RESULT.

THE APPLIANCE MUST BE INSTALLED OUTDOORS, IN THE OPEN AIR, WITH NATURAL VENTILATION. COMBUSTION PRODUCTS MUST BE DISPERSED BY MEANS OF NATURAL CONVECTION OR BY THE WIND.

Remote Control



WARNING!!

THE APPLIANCE EXHAUST END PIECE MUST BE FREE FROM OBSTRUCTIONS IN ORDER TO GUARANTEE CORRECT EXPULSION OF FLUE GASES.

Display

88 °C	- Water temperature indication (°C)
88 x10L L/min	- Water amount indication (Bath function)
	- Signal error codes
	Withdrawal in progress
	Flame presence signal
	Fun active
SET	The display shows the set temperature
RESET	Reset procedure in progress
	Fume discharge fault

Ignition procedure

- ensure that the inlet cold water valve is open
- ensure that the gas valve is open
- ensure that the device is powered by electric current.

When pressing ON/OFF key "2", the display lights.

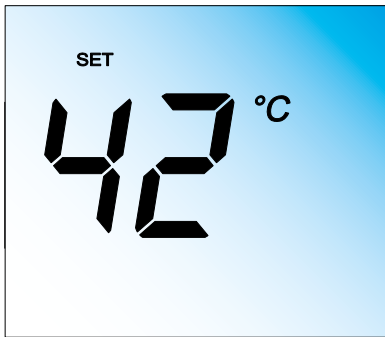

The device is ready to operate
The set temperature is indicated on the display.

By opening a hot water tap, the device automatically starts operating.

The display shows the set temperature and the flame indicates the burner ignition.



WARNING!!



**The factory set temperature is 55°C.
TO SET THE WATER TEMPERATURE AT 42°C press the button 3.**

Note: If the device does not operate, ensure that the gas and/or cold water valves are open.
Ensure that the device is electrically powered.

When closing the tap, the device automatically switches off and the flame symbol disappears from the display.

WARNING!!



**Water with a temperature higher than 50° cause serious burns.
Always verify water temperature before use.**

Water temperature adjustment

Press keys 3 and 4 to set the hot water temperature.
The new value will be indicated on the display.



It's possible to increase the temperature until 50 °C.
To select temperatures higher than 50°C push simultaneously the buttons 4 and ON/OFF for few seconds.
The display shows 51 °C and pressing the button 4 again the temperature is increased (in steps of 1°C) up to a maximum of 55 °C.

WARNING!!



TO USE WATER TEMPERATURE >55°C IS NECESSARY TO CONTACT A QUALIFIED TECHNICIAN.

Bath Function

The Bath function can be used to specify an amount of hot water to be dispensed at a selected temperature.



While the appliance is in standby, press the Bath button; 10x10L (100LT) and the flame symbol appear on the display.

Use buttons 3 and 4 to set the amount, from 1 (10 litres) to a 99 (990 litres).

Press the Bath button to save.

The selected temperature appears on the display and can be adjusted, if necessary, using buttons 3 and 4.

Press the Bath button to save the selected temperature.
On the display flash the the water amount and the selected temperature.

Open an hot water tap, the Bath function starts the metering, shown on the display.

During the tapping is possible to adjust the temperature.
The appliance will beep to indicate that the settled litres has almost been reached:

- 5 litres from the set amount: one beep
- 1 litre from the set amount: intermittent beep.

When the set amount has been reached, the beep stops.
The appliance reset the hot water temperature to the value setted before the Bath function.

The function can be disabled:

- by pressing the Bath button twice within 3 seconds.
- if the DHW request stops before the set amount is reached.
- if there aren't DHW request within 3 minutes from the Bath Function setting.

Switching off procedure

Press the ON/OFF button, to switch off the appliance.

The display indicates only two hyphens.

ATTENTION!!

Switch off the appliance completely by switching the external electrical switch to the OFF position. Shut off the gas valve.



Appliance shut-off conditions

The appliance is protected from malfunctions by means of internal checks performed by the electronic P.C.B., which stops the appliance from operating if necessary.

In case of shut-off, the flame symbol disappears from the display, which indicates an error code – see table below.

To reset the system, switch ON/OFF the device.

If the appliance still indicates the error code, switch it off. Make sure that the external electric switch is in the OFF position, close the gas valve and contact a qualified technician.



IF THE ERROR CODE IS NOT INDICATED IN THE TABLE, CLOSE THE GAS VALVE, TURN THE EXTERNAL ELECTRIC SWITCH IN THE OFF POSITION AND CONTACT A QUALIFIED TECHNICIAN.

IF THE ERROR IS NOT ELIMINATED, DO NOT ACTIVATE THE APPLIANCE.

Anti-freeze protection

Should the appliance be installed where pipes are subjected to freezing, it is recommended to empty it.

Proceed as indicated below:

- Turn the external electric switch to the OFF position
- Close the gas valve.
- Close the cold water inlet valve
- Open the DHW valves until both the device and pipes are completely emptied.

To fill the device again, open the cold water inlet valve together with DHW valves until the water exits.

Changing the gas supply

These appliances are designed to operate with different types of gas. The gas must be changed by a qualified professional.

Maintenance

Schedule an annual maintenance check-up for the appliance with a competent person.

Correct maintenance always results in savings in the cost of running the system.

Failure to arrange an annual service for the appliance will invalidate the second year of the manufacturers guarantee.

Error table

Error code	Description	
	After pressing the ON/OFF key, the control board switches off	- Ensure that the device is electrically powered.
A 1	No flame detected	- Ensure that the gas valve is open - Hold down the ON / OFF. The appliance starts the RESET procedure. Release the button as soon as RESET message appears.

Installation and servicing instructions (Only for qualified technician)

overview	9	commissioning	18
Advice for the installer	9	Ignition procedure	18
Safety regulations	10	Electricity supply	18
product description	12	Filling the hydraulic circuit	18
Overall view	12	Gas supply	18
Dimensions	12	First Ignition	18
Installation	13	Checking the gas settings	19
Before installing the appliance	13	Supply pressure check	19
Installation site	13	Checking the maximum/minimum burner pressure	20
Minimum clearances	14	Checking soft ignition power	20
Gas connection	14	Gas settings table	21
Water connection	14	Gas changeover	21
View of hydraulic connections	14	appliance protection devices	22
Excessive pressure device	14	Table summarising error codes	22
Water circuit diagram	15	maintenance	23
Electrical connections	16	Instruction for opening the casing and performing an internal inspection	23
Remote Control	16	General comments	23
Electrical diagram	17	Operational test	23
Microswitches to set maximum water temperature	17	Draining procedures	24
		Disposal and recycling the appliance	24
		Procedure for the water flow servomotor installed	25
		technical data	26

IMPORTANT INFORMATION FOR THE INSTALLER.

This appliance may only be installed by a gas installer registered with the South African Qualification and Certification Committee (SAQCC). The appliance must be installed in accordance with the requirements of SANS 10087-1 for use with LPG, SANS 827 for use with NG and any fire department regulations and/or local by laws applicable to the area. If in doubt, check with the relevant authority before undertaking the installation. Upon completion of the installation you are required to fully explain and demonstrate to the user the operational details and safety practices applicable to the appliance and the installation.

ATTENTION!! 
THE INSTALLATION AND FIRST IGNITION OF THE BOILER MUST BE PERFORMED BY QUALIFIED PERSONNEL IN COMPLIANCE WITH CURRENT NATIONAL REGULATIONS REGARDING INSTALLATION, AND IN CONFORMITY WITH ANY REQUIREMENTS ESTABLISHED BY LOCAL AUTHORITIES AND PUBLIC HEALTH ORGANISATIONS.

Advice for the installer

This appliance is designed to produce hot water for domestic use.

It should be connected to a distribution network for domestic hot water that must be compatible with its performance and power levels.

The use of the appliance for purposes other than those specified is strictly forbidden. The manufacturer cannot be held responsible for any damage caused by improper, incorrect and unreasonable use of the appliance or by the failure to comply with the instructions given in this manual. Installation, maintenance and all other interventions must be carried out in full conformity with the governing legal regulations and the instructions provided by the manufacturer.

Incorrect installation can harm persons, animals and possessions; the manufacturing company shall not be held responsible for any damage caused as a result.

The appliance is delivered in a carton. Once you have removed all the packaging, make sure the appliance is intact and that no parts are missing. If this is not the case, please contact your supplier.

Keep all packaging material (clips, plastic bags, polystyrene foam, etc.) out of reach of children as it may present a potential hazard.

In the event of a fault and/or malfunction, turn the appliance off, turn off the gas cock and do not attempt to repair it yourself. Contact a qualified professional instead.

Before any maintenance or repair work is performed on the appliance, make sure you have disconnected it from the electricity supply by switching the external bipolar switch to the "OFF" position and removing the fuse.

All repairs, which should only be performed using original spare parts, should be carried out by a qualified professional. Failure to comply with the above instructions could compromise the safety of the appliance and invalidate all liability on the part of the manufacturer.

In the event of any maintenance or other structural work in the immediate vicinity of the ducts or flue gas exhaust devices and their accessories, switch the appliance off by switching the external bipolar switch to the "OFF" position and shutting off the gas control valve.

When the work has been completed, ask a qualified technician to check the efficiency of the ducting and the devices.

Turn the appliance off and turn the external switch "OFF" to clean the exterior parts of the appliance.

Clean using a cloth dampened with soapy water. Do not use aggressive detergents, insecticides or toxic products.

If the appliance is used in full compliance with current legislation, it will operate in a safe, environmentally-friendly and cost-efficient manner.

If using kits or optional extras, make sure they are authentic.

WARNING!!

Water with a temperature higher than 50° cause serious burns.

Always verify water temperature before use.

WARNING!!

The device must be activated only in presence of water in the exchanger.

IMPORTANT!!

If the appliance is installed in a **hard water area (> 200 mg/l)**, a softener should be installed to limit the amount of limescale building up in the heat exchanger.

The guarantee does not cover damage caused by limescale.

Safety regulations

Key to symbols:

Failure to comply with this warning implies the risk of personal injury, in some circumstances even fatal 

Failure to comply with this warning implies the risk of damage, in some circumstances even serious, to property, plants or animals. 

Install the appliance on a solid wall which is not subject to vibration. 
Noisiness during operation.

When drilling holes in the wall for installation purposes, take care not to damage any electrical wiring or existing piping.

Electrocution caused by contact with live wires. Explosions, fires or asphyxiation caused by gas leaking from damaged piping. 

Damage to existing installations. 

Flooding caused by water leaking from damaged piping. 

Perform all electrical connections using wires which have a suitable section.

Fire caused by overheating due to electrical current passing through undersized cables. 

Protect all connection pipes and wires in order to prevent them from being damaged. 

Electrocution caused by contact with live wires. Explosions, fires or asphyxiation caused by gas leaking from damaged piping. 

Flooding caused by water leaking from damaged piping.

Make sure the installation site and any systems to which the appliance must be connected comply with the applicable norms in force. 

Electrocution caused by contact with live wires which have been installed incorrectly. 

Damage to the appliance caused by improper operating conditions.

Use suitable manual tools and equipment (make sure in particular that the tool is not worn out and that its handle is fixed properly); use them correctly and make sure they do not fall from a height. Replace them once you have finished using them.

Personal injury from the falling splinters or fragments, inhalation of dust, shocks, cuts, pricks and abrasions. 

Damage to the appliance or surrounding objects caused by falling splinters, knocks and incisions. 

Use electrical equipment suitable for its intended use (in particular, make sure that the power supply cable and plug are intact and that the parts featuring rotary or reciprocating motions are fastened correctly); use this equipment correctly; do not obstruct passageways with the power supply cable, make sure no equipment could fall from a height. Disconnect it and replace it safely after use.

Personal injury caused by falling splinters or fragments, inhalation of dust, knocks, cuts, puncture wounds, abrasions, noise and vibration. 

Damage to the appliance or surrounding objects caused by falling splinters, knocks and incisions. 

Make sure any portable ladders are positioned securely, that they are suitably strong and that the steps are intact and not slippery and do not wobble when someone climbs them. Ensure someone provides supervision at all times.

Personal injury caused by falling from a height or cuts (stepladders shutting accidentally). 

Make sure any rolling ladders are positioned securely, that they are suitably strong, that the steps are intact and not slippery and that the ladders are fitted with handrails on either side of the ladder and parapets on the landing.

Personal injury caused by falling from a height. 

During all work carried out at a certain height (generally with a difference in height of more than two metres), make sure that parapets are used to surround the work area or that individual harnesses are used to prevent falls. The space where any accidental fall may occur should be free from dangerous obstacles, and any impact upon falling should be cushioned by semi-rigid or deformable surfaces.

Personal injury caused by falling from a height. 

Make sure the workplace has suitable hygiene and sanitary conditions in terms of lighting, ventilation and solidity of the structures.

Personal injury caused by knocks, stumbling etc. 

Protect the appliance and all areas in the vicinity of the work place using suitable material.

Damage to the appliance or surrounding objects caused by falling splinters, knocks and incisions. 

Handle the appliance with suitable protection and with care.

Damage to the appliance or surrounding objects from shocks, knocks, incisions and squashing. 

During all work procedures, wear individual protective clothing and equipment.

Personal injury caused by electrocution, falling splinters or fragments, inhalation of dust, shocks, cuts, puncture wounds, abrasions, noise and vibration. 

Place all debris and equipment in such a way as to make movement easy and safe, avoiding the formation of any piles which could yield or collapse.

Damage to the appliance or surrounding objects from shocks, knocks, incisions and squashing. 

All operations inside the appliance must be performed with the necessary caution in order to avoid abrupt contact with sharp parts.

Personal injury caused by cuts, puncture wounds and abrasions. 

Reset all the safety and control functions affected by any work performed on the appliance and make sure they operate correctly before restarting the appliance.

Explosions, fires or asphyxiation caused by gas leaks or an incorrect flue gas exhaust. 

Damage or shutdown of the appliance caused by out-of-control operation. 

Before handling, empty all components that may contain hot water, carrying out any bleeding if necessary.

Personal injury caused by burns. 

Descalc the components, in accordance with the instructions provided on the safety data sheet of the product used, airing the room, wearing protective clothing, avoid mixing different products, and protect the appliance and surrounding objects.

Personal injury caused by acidic substances coming into contact with skin or eyes; inhaling or swallowing harmful chemical agents. 

Damage to the appliance or surrounding objects due to corrosion caused by acidic substances. 

If you detect a smell of burning or smoke, keep clear of the appliance, disconnect it from the electricity supply, open all windows and contact the technician.

Personal injury caused by burns, smoke inhalation, asphyxiation. 



Permit Number:
1317-2/1-RSA-17-A

Check for the Safe Appliance Mark (above) and the Verification Permit number-on the product or in the instruction manual.

The hose and regulator should also be 'approved'.

Check the suitability: LPGas or Natural Gas.

Do not tamper with the appliance in any way. It may have warranty implications.

This appliance can be used by children aged from 8 years and above and person with reduced physical, sensory or mental capabilities or lack of experience and knowledge if they have been given supervision or instruction concerning use of the appliance in a safe way and understand the hazards involved. Children shall not play with the appliance. Cleaning and user maintenance shall not be made by children without supervision.

PRODUCT DESCRIPTION

Overall view

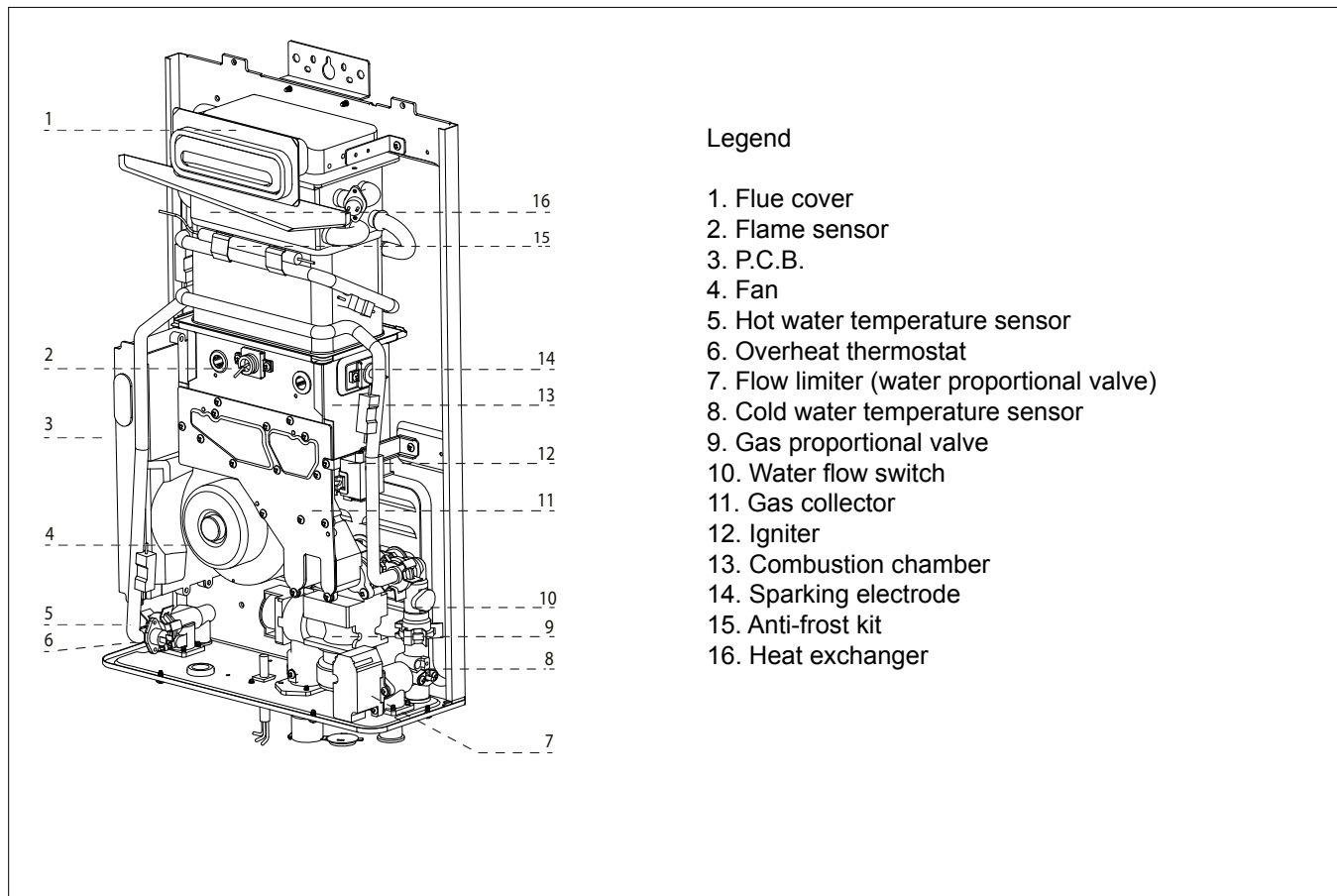

Overall dimensions

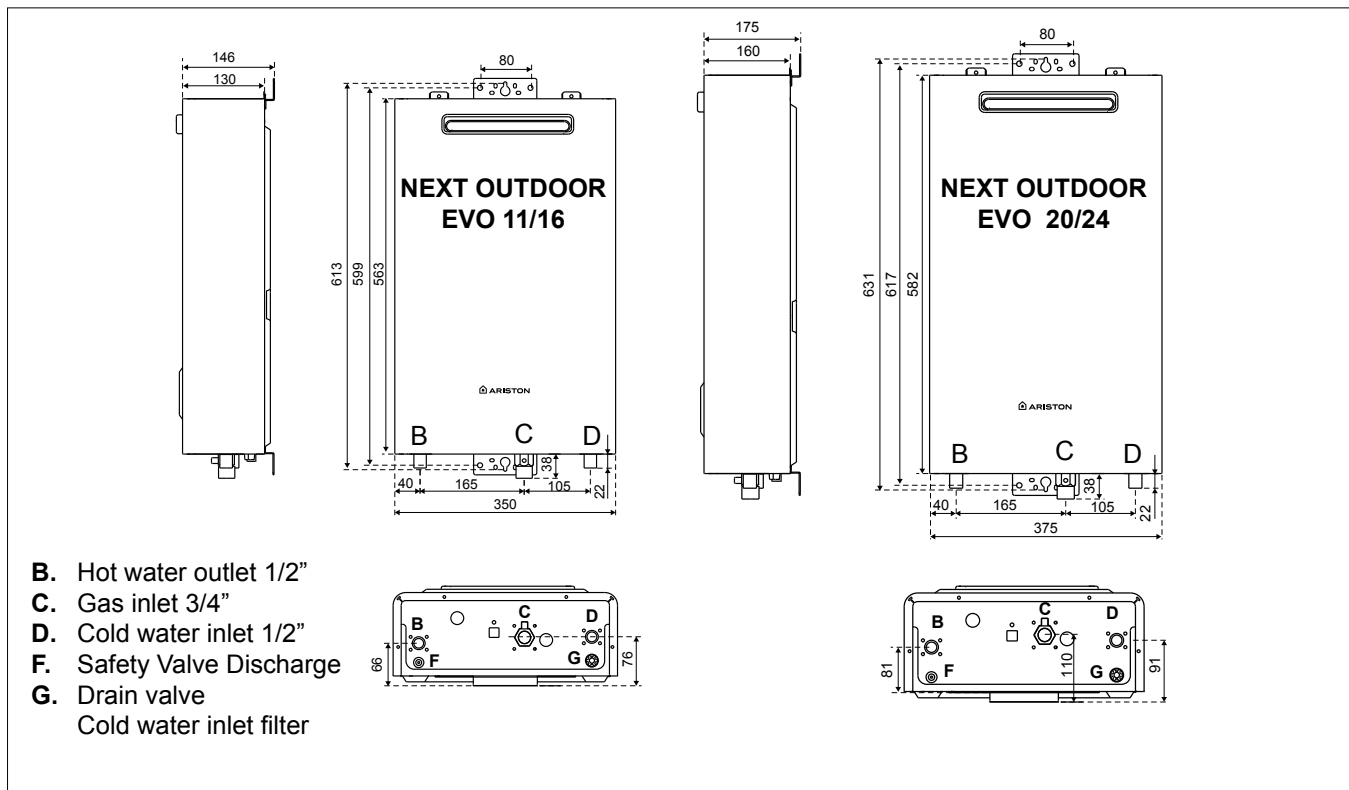

Before installing the appliance

The appliance heats water to a temperature below boiling. It should be connected to a domestic water mains supply, that must correspond in size to the performance and its power of the appliance.

Before connecting the appliance, it is first necessary to perform the following operations:

- Carefully wash the system piping in order to remove any screw thread or welding residues, or any dirt which might prevent the appliances from operating correctly.
- Make sure that the appliance is set up for operation with the type of gas available (read the information on the packaging label and on the boiler data plate).
- In areas with particularly hard water, limescale may build up on the components inside the appliance and reduce its overall efficiency.

A-TYPE APPLIANCES NOT INTENDED FOR CONNECTION TO A FLUE GAS EXHAUST OR A DEVICE FOR CHANNELLING COMBUSTION PRODUCTS OUTSIDE THE PREMISES IN WHICH IT IS INSTALLED.

THE APPLIANCE CAN ONLY BE INSTALLED OUTDOORS OR IN A PARTIALLY-SHELTERED AREA, AND THE SPACE IN WHICH IT IS INSTALLED MUST NOT BE ENCLOSED.

Flue gases are discharged through a forced draught system.

The appliance must be installed on a solid, non-combustible, permanent wall to prevent access from the rear.

When creating a space for the boiler, the minimum distances (which ensure that various parts of the appliance may be accessed after it has been installed) should be respected.

WARNING!!

NO INFLAMMABLE ITEMS SHOULD BE LEFT IN THE VICINITY OF THE APPLIANCE. MAKE SURE THE INSTALLATION SITE AND ANY SYSTEMS TO WHICH THE APPLIANCE MUST BE CONNECTED ARE FULLY COMPLIANT WITH THE CURRENT APPLICABLE LEGISLATION.

IF DUST AND/OR AGGRESSIVE VAPOURS ARE PRESENT IN THE ROOM IN WHICH IT IS TO BE INSTALLED, THE APPLIANCE MUST OPERATE INDEPENDENTLY OF THE AIR INSIDE THE ROOM.

WARNING!!

THE INSTALLATION AND FIRST IGNITION OF THE APPLIANCE MUST BE PERFORMED BY QUALIFIED PERSONNEL IN COMPLIANCE WITH CURRENT NATIONAL REGULATIONS REGARDING INSTALLATION, AND IN CONFORMITY WITH ANY REQUIREMENTS ESTABLISHED BY LOCAL AUTHORITIES AND PUBLIC HEALTH ORGANISATIONS.

Installation site

THE APPLIANCE MAY ONLY BE INSTALLED OUTDOORS. OBSERVE ALL CURRENT REGULATIONS WHEN CHOOSING THE APPLIANCE INSTALLATION SITE.

INSTALLATION

Minimum clearances

In order to allow easy access to the appliance for maintenance operations.

The appliance must be installed in accordance with the clearances stated below.

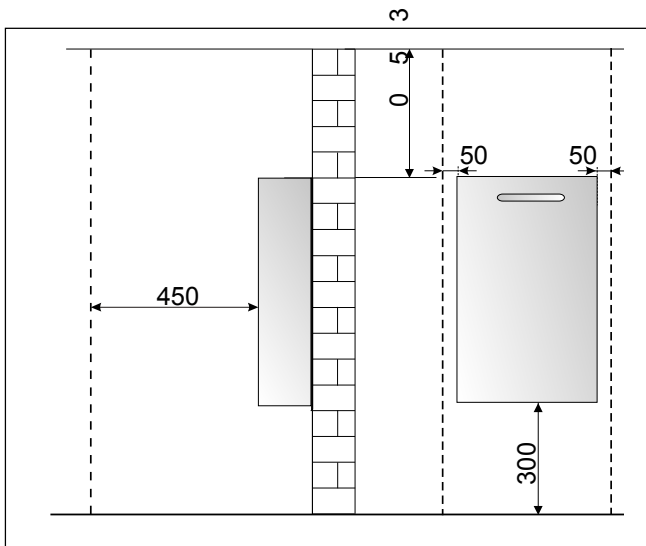

Gas connection

The appliance was designed to use gases belonging to the categories as shown in the following table.

COUNTRY	MODEL	CATEGORIES
South Africa	NEXT OUTDOOR 11 LPG ZA EVO NEXT OUTDOOR 16 LPG ZA EVO NEXT OUTDOOR 20 LPG ZA EVO NEXT OUTDOOR 24 LPG ZA EVO	LPG

Make sure, using the labels on the packaging and the data plate on the appliance itself, that the appliance is in the correct country and that the gas category for which the appliance was designed corresponds to one of the categories available in the country where it will be used.

The gas supply piping must be created and measured out in compliance with specific legal requirements and in accordance with the maximum power of the appliance; you should also make sure that the shut-off valve is the right size and that it is connected correctly.

Before carrying out the installation, it is recommended that the fuel pipes are cleaned thoroughly in order to remove any residues which could prevent the appliance from operating correctly.

Check that the supplied gas corresponds to the type of gas for which the appliance was designed (see the data plate located on the appliance itself).

It is also important to check that the pressure of the gas (methane or LPG) you will be using to feed the appliance is suitable, because if it is insufficient the power of the generator may be reduced, causing inconvenience for the user.

Water connection

The illustration shows the connections for the water and gas attachments of the appliance.

Check that the maximum water mains pressure does not exceed 8,5 bar (see *technical data page 27*); if it does, a pressure reducing valve must be installed.

Ensure that the minimum pressure is not lower than 0,1 mbar.

View of the hydraulic Connections

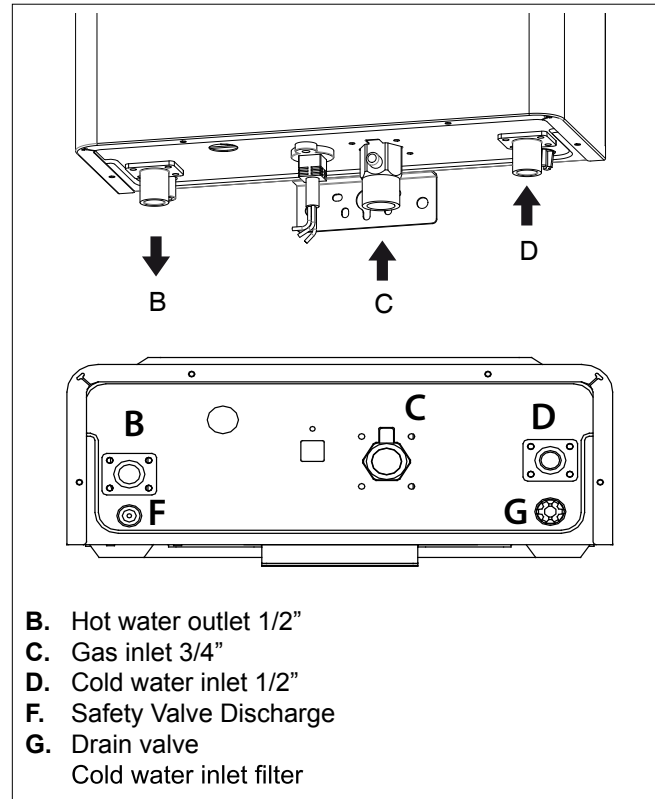

The device is equipped with a filter “G”, located on the cold water entrance. Periodically clean the hydraulic system, if dirt is present.

IMPORTANT!!

DO NOT ACTIVATE THE DEVICE WITHOUT THE FILTER.

IMPORTANT!!

If the appliance is installed in a hard water area (> 200 mg/l), a softener should be installed to limit the amount of limescale building up in the heat exchanger. The guarantee does not cover damage caused by limescale.

Excessive pressure device

The excessive pressure device outlet (F) must be connected to a drainage siphon which can be checked visually in order to prevent maintenance procedures causing harm to people, animals or property (the manufacturer will not be held liable for any such damage).

Water circuit diagram

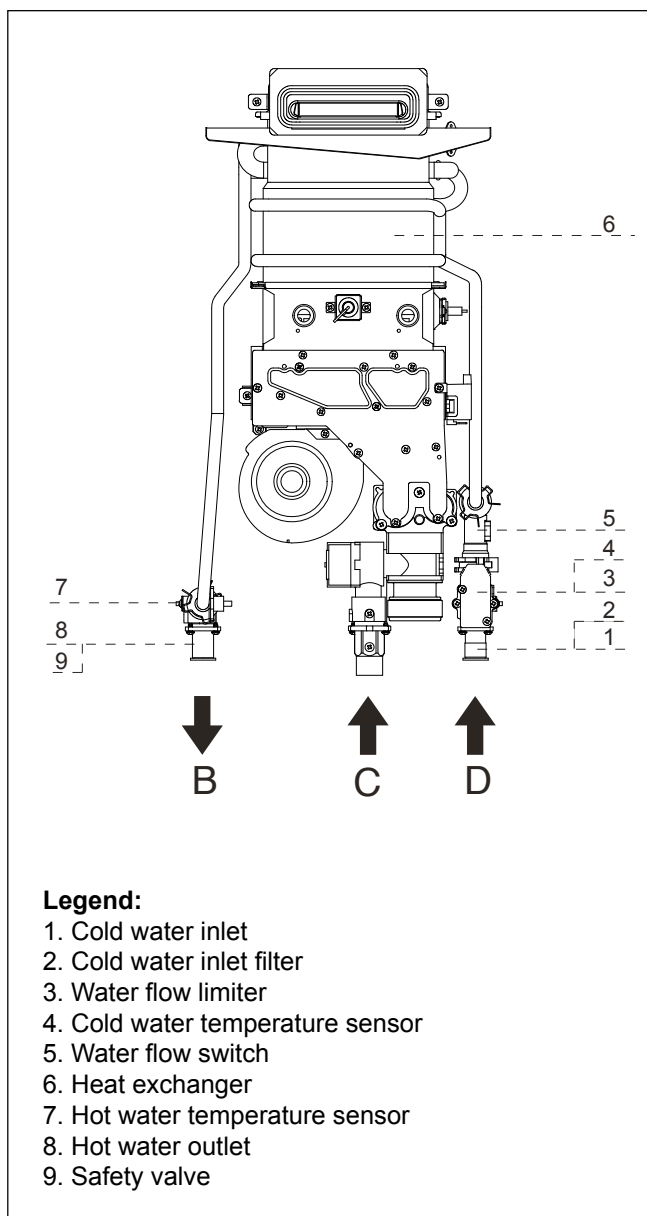

WARNING



BEFORE PERFORMING ANY WORK ON THE APPLIANCE, FIRST DISCONNECT IT FROM THE ELECTRICAL POWER SUPPLY USING THE EXTERNAL BIPOLAR SWITCH.

Electrical connections

For increased safety, ask a qualified technician to perform a thorough check of the electrical system.

The manufacturer is not responsible for any damage caused by the lack of a suitable earthing system or by the malfunctioning of the electricity mains supply.

Make sure that the system is able to withstand the maximum power absorbed by the appliance (this is indicated on the appliance data plate).

Check that the section of the wires is suitable and is not less 0,75 mm²

The appliance must be connected to an efficient earthing system if it is to operate correctly.

The power supply cable must be connected to a 230V-50Hz network, where the L-N poles and the earth connection are all respected.

If the supply cord is damaged, it must be replaced by a special cord or assembly available from the manufacturer or its service agent.

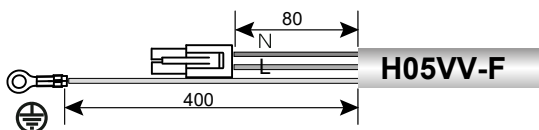

Important!



Connection to the electricity mains supply must be performed using a fixed connection (not with a mobile plug) and a bipolar switch that provide full disconnection under overvoltage category III conditions.

The use of multiplugs, extension leads or adaptors is strictly prohibited.

It is strictly forbidden to use the piping from the hydraulic, heating and gas systems for the appliance earthing connection.

The appliance is not protected against the effects caused by lightning. If the mains fuses need to be replaced, use 2A rapid fuses.

Remote control

The appliance is supplied with a Remote Control and the corresponding connection cable (30 m).

Positioning the Remote Control

Make sure that:

- the remote control cannot be accessed by children
- it is NOT installed near sources of heat
- it is NOT installed in areas which could become wet (spraying).

Separate the fixing base by inserting a screwdriver into the two side cracks and fix the Remote Control base to the wall in the chosen area, using the screws supplied with the appliance.



If necessary, cut the cable supplied to the desired length and apply the connectors supplied in the package to ensure power is supplied properly and safely.

Remote Control connection

Proceed as follows:

- disconnect the appliance from the electricity supply by switching the external bipolar switch to OFF.
- remove the casing as indicated in par. "Instructions for opening the casing and performing internal inspection".
- insert the cable into the appliance, via cable gland L.

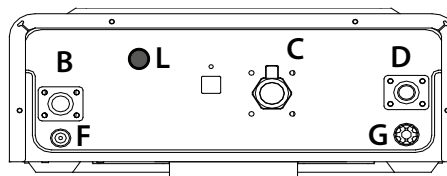

- connect the cable to the P.C.B. – see electrical diagram on following page.

Electrical diagram

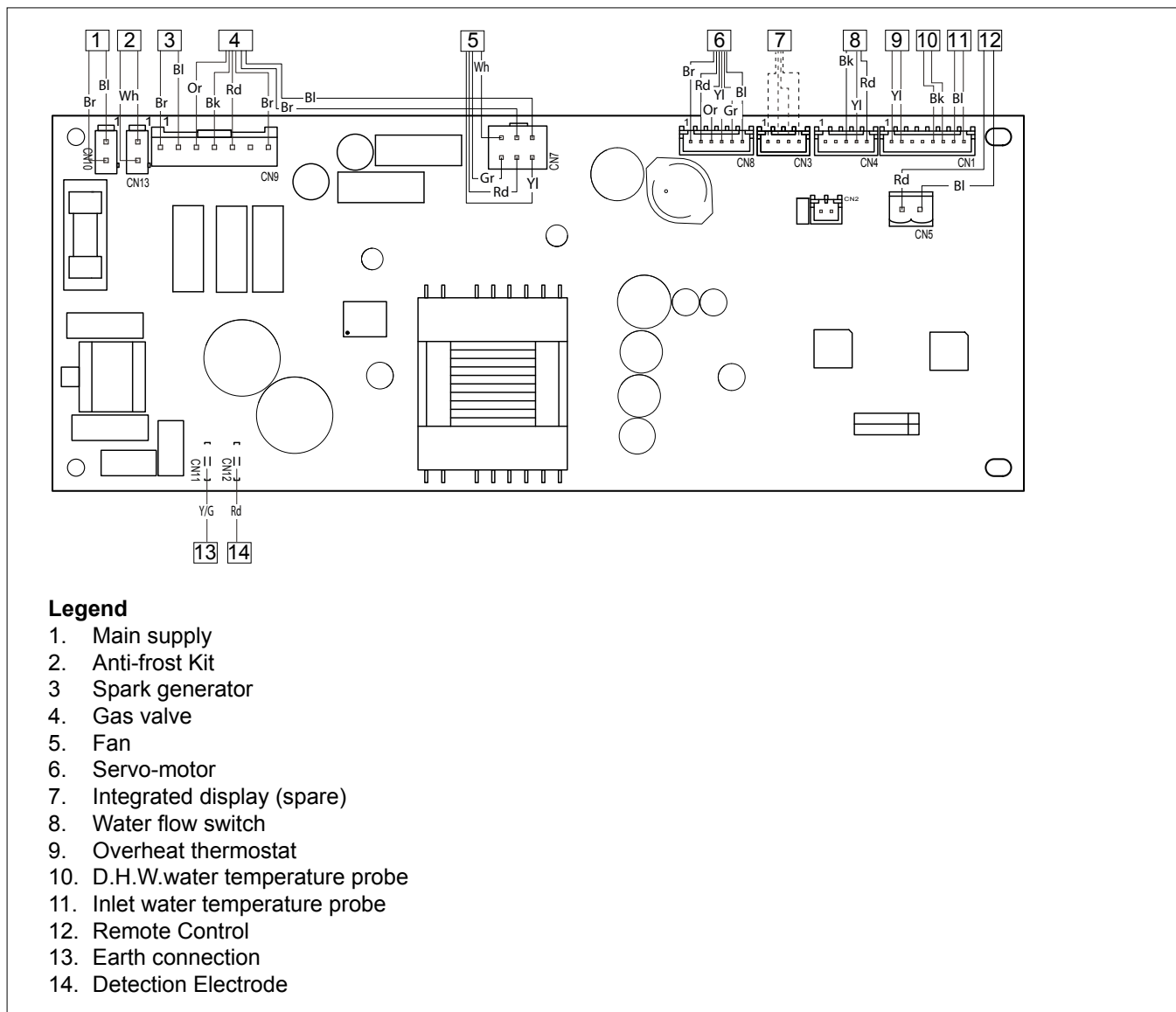

Microswitches to set maximum water temperature

The microswitches are positioned on the Remote Control - Display P.C.B.
 Proceed as follows:

1. Remove the front casing of the Remote Control
2. Unscrew all the screws and open the Remote Control.

IMPORTANT!!

BE CAREFUL TO THE CONNECTION CABLE AT THE MAIN P.C.B.

3. Unscrew the screw to remove the P.C.B. from the Remote Control.
4. Access to the front of the P.C.B. and change the microswitches setting.

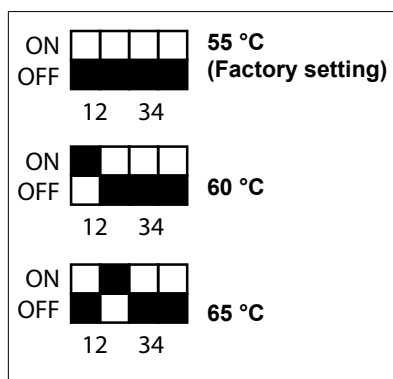

Ignition procedure

Press the ON/OFF key placed on the control panel, to display the set temperature.

For temperature adjustments see the User Manual paragraph.

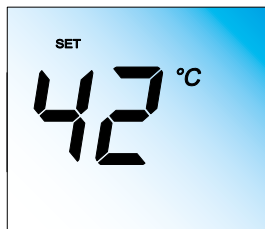

Initial procedures

To guarantee safety and the correct operation of the appliance, it must be prepared for operation by a qualified technician who possesses the skills which are required by law.

Electricity supply

- Check that the voltage and frequency of the electricity supply correspond to the data shown on the appliance data plate;
- Make sure that the earthing connection is efficient.

Filling the hydraulic circuit

Proceed in the following manner:

- **Gradually** open the valve located on the cold inlet;
- open a D.H.W. tap.

WARNING!!

DO NOT USE THE APPLIANCE WITHOUT WATER.

Gas supply

Proceed in the following manner:

- Make sure that the main gas supply uses the same type of gas as indicated on the appliance data plate;
- Open all doors and windows;
- Make sure there are no sparks or naked flames in the room;
- Make sure that the system does not leak fuel using a cut-off valve inside the appliance itself which should be closed and then opened while the gas valve is disabled. The meter must not show any signs of gas being used for 10 minutes.

First ignition

The first start-up must be carried out by a qualified technician.

1. Make sure that:
 - The gas valve is closed;
 - The electrical connection has been properly carried out. Make sure that, in any case, the green/yellow earthing wire is connected to an efficient earthing system;
 - The exhaust duct for combustion products should be suitable and free from any obstructions;
2. Switch on the appliance (by pressing the ON/OFF button)
3. Open a D.H.W. tap.
4. The appliance indicates the ignition lock failure
5. Close the D.H.W. tap.
6. Hold down the ON / OFF button. The appliance starts the RESET procedure. Release the button as soon as RESET message appears on the display.
7. Open the gas valve and check the connection seals, including the appliance connection seals, making sure that the meter does not detect any passage of gas. Eliminate any leaks.
8. Start the appliance by opening a D.H.W. tap.

WARNING!!



Water with a temperature higher than 50° cause serious burns.

Always verify water temperature before use.

**Accessing the settings - adjustment parameters
RESERVED FOR TECHNICAL ASSISTANCE**

To access the Parameters proceed as follow:

- switch Off the appliance
- switch On the appliance and within 1 minute simultaneously press the **3** and **4** buttons for 3 seconds
- the display shows **L 0**.

To select the others parameters press **4** button.

To access to the parameters press the ON/OFF button, the display shows the value of the parameter.

To modify the value press the **3** and **4** buttons.

To save the new value press ON/OFF.

parameter	description	value	factory setting
	notes		

L0	Model and type of gas selection		
	RESERVED FOR TECHNICAL ASSISTANCE Only if the gas or PCB is changed see "gas setting" table		
L1	Post-ventilation time setting.	0 = 90 sec. (if set temperature ≥ 50°C)	0
		0 = 30 sec. (if set temperature < 50°C) FACTORY SETTING 1 = 30 sec.	
L2	Adjust the Gas burner pressure MIN	from -9 to 9	
	Read the pressure on the manometer and verify on "gas setting" table		
L3	Adjust the Gas burner pressure MAX	from -9 to 9	
	Read the pressure on the manometer and verify on "gas setting" table		
L4	NOT ACTIVE		
L5	NOT ACTIVE		
L6	Soft ignition		
	Read the pressure on the manometer and verify on "gas setting" table		
L7	NOT ACTIVE		
L8	DHW Start delay time	from 0 to 50 10 = 1 sec.	5
L9	Main P.C.B. software version		
LA	HMI software version (Remote Control)		
Lb	Fan speed automatic adjustment	0= default 1 = re-adapt	0
	This parameter must be used if the following components are replaced / reassembled: PCB, fan, combustion chamber, heat exchanger, exhaust cover.		
LC	Stepper motor reset	0= Auto	00
Ld	Maximum limited pressure		
LE	Minimum limited pressure		

Checking the gas settings

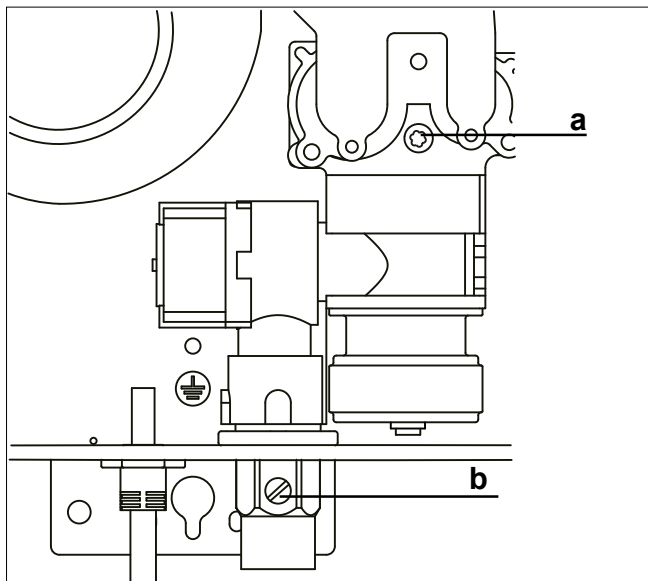

Supply pressure check

1. Close the manual gas valve
2. Loosen screw “b” and insert the pressure gauge connection pipe into the pipe tap.
3. Open the manual gas valve.
4. Switch the appliance ON by opening a DHW tap.
The supply pressure must correspond to the value established in relation to the type of gas for which the appliance is designed.

WARNING!!



!The supply pressure must correspond to the value indicated on the Gas Summary Table, OTHERWISE DO NOT ACTIVATE THE DEVICE.

5. Switch the appliance OFF by closing the DHW tap.
6. Close the manual gas valve.
7. When the check is over, tighten screw “b” and make sure it is securely in place
8. Open the manual gas valve and check the tightness of the screw.

Checking the maximum and minimum burner pressure

(see the Gas setting table)

1. Unplug the appliance and close the manual gas valve.
2. Loosen screw “a” and insert the manometer connection pipe into the pipe tap.
3. Plug the appliance and open the manual gas valve.
4. Press the On/Off button the display will illuminate
5. Simultaneously press the **+** 3 and **-** 4 buttons for 3 seconds. The display shows **L0**.
6. Press the **+** 3 button to select **L3**.
7. Press the On/Off button to access to the parameter **L3**, appliance forced to maximum power.
Open an hot water tap.
8. On the manometer verify the pressure and if necessary press the the **+** 3 and **-** 4 buttons to adjust maximum burner pressure as indicated on the gas settings table.
9. Press the ON/FF button to save the setting.
10. Press the the **-** 4 button to select **L2**.
11. Press the On/Off button to access to the parameter **L2**, appliance forced to minimum power.
12. On the manometer verify the pressure and if necessary press the **+** 3 and **-** 4 buttons to adjust maximum burner pressure as indicated on the gas settings table.
13. Press the ON/FF button to save the change.
14. Press **+** 3 and **-** 4 buttons at the same time to quit from setting menu.
15. Close Hot water tap.
Switch off the appliance through ON/OFF button.
16. When the check is over, tighten screw “a” and make sure it is securely in place
17. Open the gas valve and check the tightness of the screw.

Checking soft ignition power

(see the Gas setting table)

1. Close the gas valve.
2. Loosen screw “a” and insert the manometer connection pipe into the pipe tap.
3. Open the gas valve.
4. Press the On/Off button the display will illuminate
5. Simultaneously press the **+** 3 and **-** 4 buttons for 3 seconds. The display shows **L0**.
6. Press the **+** 3 button to select **L6**. Open one hot water tap.
7. Press the On/Off button to access to the parameter **L6**, appliance forced to ignition power.
8. On the manometer verify the pressure and if necessary press the **+** 3 or **-** 4 buttons to adjust the slow ignition pressure as indicated on the gas settings table.
9. Press the ON/FF button to save the change.
10. Press **+** 3 and **-** 4 buttons at the same time to quit from setting menu.
11. Close Hot water tap. Switch off the appliance through ON/OFF button.
12. When the check is over, tighten screw “a” and make sure it is securely in place
13. Open the gas valve and check the tightness of the screw.

Gas settings table

		NEXT OUTDOOR								NEXT OUTDOOR					
		11 ZA EVO				16 ZA EVO				20 ZA EVO			24 ZA EVO		
		G20	G230	G30	G31	G20	G230	G30	G31	G20	G30	G31	G20	G30	G31
lower Wobbe index (15°C, 1013 mbar)	MJ/m ³	45.67	38.90	80.58	70.69	45.67	38.90	80.58	70.69	45.67	80.58	70.69	45.67	80.58	70.69
Gas inlet pressure	mbar	20	20	28/30	37	20	20	28/30	37	20	28/30	37	20	28/30	37
Gas burner pressure max	mbar	8.20	8.20	8.00	10.30	7.40	7.40	7.80	9.40	5.90	6.90	8.20	7.40	8.90	10.80
Gas burner pressure min	mbar	2.90	2.90	3.20	4.10	2.40	2.40	2.90	3.00	2.70	3.00	3.50	2.70	3.00	3.50
Slow ignition pressure	mbar	6.90	6.90	7.50	8.60	6.95	6.95	7.60	9.00	4.46	5.29	6.33	5.68	6.40	7.92
LO Parameter - Setting model and type of gas	nr.	27	27	37	32	29	29	39	34	30	40	35	31	41	36
Maximum limited pressure	mbar	9.00	9.00	9.00	12.00	9.00	9.00	9.00	12.00	9.00	12.00	12.00	9.00	12.00	12.00
Minimum limited pressure	mbar	2.40	2.40	2.40	3.00	2.00	2.00	2.40	2.40	2.00	2.40	2.80	2.00	2.40	2.80
Main Burner jets	nr.	10				15				18			18		
Ø burner jets	mm	1.5	1.65	1.1	1.1	1.5	1.60	1.1	1.1	1.7	1.18	1.18	1.7	1.18	1.18
Consumption (15°C, 1013 mbar) (G.N.= m ³ /h) (LPG kg/h))	max	2.30	1.79	1.56	1.54	3.35	2.58	2.25	2.22	4.23	2.91	2.86	4.90	3.42	3.37
	min	0.54	0.42	0.36	0.36	0.73	0.55	0.47	0.47	0.92	0.65	0.64	0.92	0.65	0.64

Change of gas type

The appliance may be adjusted so that it may be used with Liquid Gas (G30-G31) instead of methane gas (G20) or vice-versa.

The adjustment must be performed by a Qualified Technician using the special Kit.

Carefully follow the instructions provided in the instructions sheet included in the kit.

Proceed as follow:

1. Close the gas cock.
2. Unplug the supply cable.
3. Remove the front cover
4. Replace the gas collector
Attention!! Not damage the ceramic fibre.
5. Replace the gas valve gasket.
6. Reconnect the cable of the detection electrode
7. Make sure that no screws or detritus have been forgotten inside the combustion chamber.
8. Plug the supply cable
9. Access to the parameter **L0** to set the new value for the gas/model - see the "Gas setting table".
10. Access to the parameter **Lb** and select 1 to activate the fan re-adapt (always with front cover open)
11. Open the gas cock.
12. Check the supply pressure for the new gas.
13. Access to the parameters **L2-L3** to adjust the minimum and maximum gas burner pressure - see "Gas setting Table"
14. **IF NECESSARY**, set the Limited pressure (min/max).
Access to the parameters **Ld-LE** to adjust the minimum and the maximum gas limited pressure using the dedicated nut/screw.
15. Access to the parameter **L6** to adjust the Slow ignition pressure - see the "Gas setting table".
16. Switch ON the device, open a DHW tap, and check operation.
17. Assemble the front cover.

WARNING!!



Check the GAS CONNECTION for leaks before firing unit.

WARNING!!



IF YOU SMELL GAS:

**Do not try to start the water heater.
Do not touch any electric switches; do not use any phone in your building.
Turn off the main gas valve.
Open all windows and call for assistance.**

Appliance shut-off conditions

The appliance is protected from malfunctions by means of internal checks performed by the electronic P.C.B., which stops the appliance from operating if necessary.

In the event of the appliance being shut off in this manner, a code appears on the control panel display which refers to the type of shut-off and the reason behind it.

Switch off the appliance. Make sure the external electric switch is in the OFF position, shut off the gas valve and contact a qualified technician.

Table summarising error codes

Error code	Description	
A 1	No flame detected	<ul style="list-style-type: none"> - Gas valve closed Open the manual valve and follow the activation procedure - Check the ignition electrode - Check the detection electrode
A 2	Overheating	<ul style="list-style-type: none"> - A temperature higher than 85°C has been detected. Check the water pressure
 A 3	Pipe blockage error	<ul style="list-style-type: none"> - Check the exhaust outlet and ambient condition
A 4	Flame lift	<ul style="list-style-type: none"> - Check the ignition electrode - Check the detection electrode - Check the supply voltage of the P.C.B. - Check the gas supply pressure - Check the exhaust cover if blocked
A 5	Hot water temperature sensor error	<ul style="list-style-type: none"> - Check the Hot Water temperature sensor
A 7	Cold water temperature sensor error	<ul style="list-style-type: none"> - Check the Cold Water temperature sensor
A 8	Communication error	<ul style="list-style-type: none"> - Check the connection between HMI P.C.B and Main P.C.B - Check the P.C.B - Check the HMI P.C.B
A A	Too many reset (> 5 reset in 15 minutes)	<ul style="list-style-type: none"> - Plug off and then plug on
E 6	False flame	<ul style="list-style-type: none"> - Check the detection electrode - Check the P.C.B.
E 7	Fan error	<ul style="list-style-type: none"> - Check the P.C.B. and fan
E 9	P.C.B. error	<ul style="list-style-type: none"> - Switch OFF the appliance and restart after 30 seconds - Check the P.C.B.
E E	P.C.B. error	<ul style="list-style-type: none"> - Switch OFF the appliance and restart after 30 seconds - Check the P.C.B.
E F	P.C.B. error	<ul style="list-style-type: none"> - Press twice the ON/OFF button and restart the appliance

Instructions for opening the casing and performing an internal inspection

Before performing any work on the appliance, first disconnect it from the electrical power supply using the external bipolar switch and shut off the gas valve.

To access the inside of the appliance, the following is necessary:

- loosen the 4 screws on the lower part of the casing,
- pull it forward and remove it.

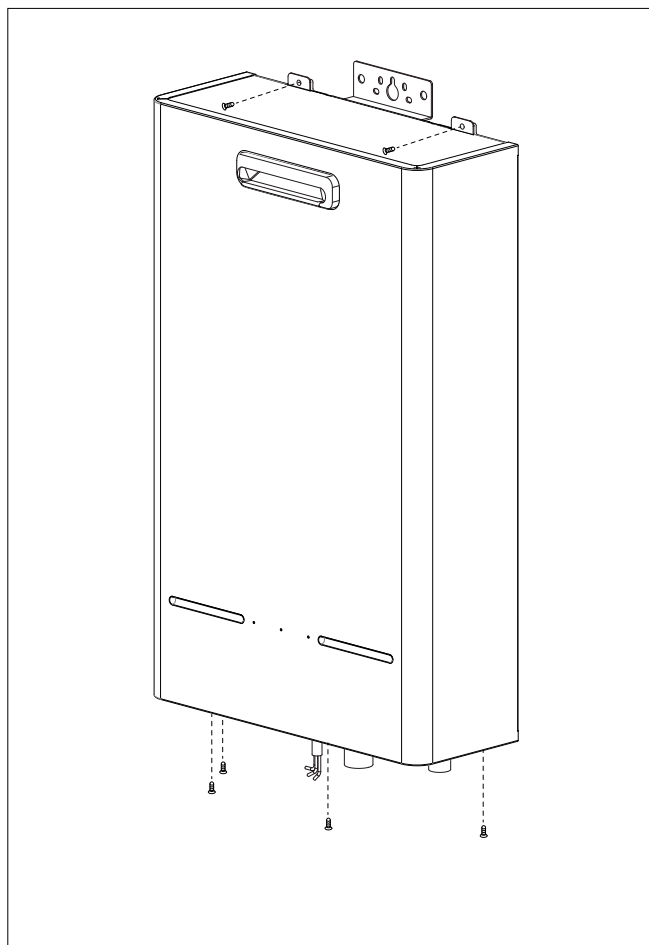

Maintenance is an essential part of the safe and efficient operation of the appliance and ensures its durability. It should be performed according to the instructions given in current legislation. Perform combustion analysis regularly in order to check the operating efficiency of the appliance and to make sure any polluting substances released are within the boundaries set by current legislation.

Before beginning maintenance work:

- Disconnect the appliance from the electricity supply by turning the external bipolar switch to the "OFF" position;
- Close the gas valve and the central heating and domestic hot water system valve.

After the work has been completed the initial settings will be restored.

General comments

It is recommended that the following inspections be carried out on the appliance at least once a year:

1. Check the seals in the water part and, if necessary, replace the gaskets and restore the seal to perfect working order.
2. Check the seals in the gas part and, if necessary, replace the gaskets and restore the seal to perfect working order.
3. Visually check the overall condition of the appliance.
4. Visually check the combustion and, if necessary, disassemble and clean the burner.
5. Following the inspection detailed in point "3", disassemble and clean the combustion chamber, if necessary.
6. Following the inspection detailed in point "4", disassemble and clean the burner and injector, if necessary.
7. Cleaning the primary heat exchanger
8. Make sure the following safety devices are operating correctly:
 - temperature limit safety device.
9. Make sure that the following gas part safety devices are operating correctly:
 - absence of gas or flame safety device (ionisation).
10. Check the efficiency of the domestic hot water production process (test the flow rate and temperature).
11. Cleaning the filter in cold water inlet.

WARNING! THE APPLIANCE MUST NOT BE PUT IN FUNCTION WITHOUT FILTER.

12. Perform a general inspection of the appliance operation.
13. Remove oxide from the detection electrode using an emery cloth.

Operational test

After having carried out the maintenance operations, fill the appliance and the water circuit.

- Begin operating the boiler.
- Check the settings and make sure all the command, adjustment and monitoring parts are working correctly.
- Check the seal and that the system for the expulsion of fumes/suction of comburent air is operating correctly.

Draining procedures

The system must be drained using the following procedure:

- Shut off the water mains inlet valve;
- Open the hot and cold water taps;
- Empty the water from the lowest points of the system (where applicable).

WARNING

Before handling, empty all components which may contain hot water, performing bleeding where necessary.

Descale the components in accordance with the instructions provided on the safety data leaflet supplied with the product used, make sure the room is well ventilated, wear protective clothing, avoid mixing different products, and protect the appliance and surrounding objects.

Seal all openings used to take a gas pressure reading or to make any gas adjustments.

Make sure that the nozzle is compatible with the supplied gas.

If a smell of burning is detected or smoke is seen leaking from the appliance, or there is a smell of gas, disconnect it from the electricity supply, shut off the gas valve, open the windows and call for technical assistance.

Information for the user

Inform the user on how to operate the appliance.

In particular, provide the user with the instruction manuals and inform him/her that these must be stored with the appliance.

Moreover, make sure the user is aware of the following:

- How to set the temperature and adjustment devices for using the appliance correctly and in a more cost-efficient way.
- The system must be serviced regularly in compliance with legislation.
- The settings relating to the supply of combustion air and combustion gas must not in any event be modified.

Disposal and recycling the appliance

Our products are designed and manufactured for most of the components of recyclable materials.

The appliance and its accessories have to be adequately disposed and the various materials differentiated, where possible.

The packaging used for the transport of the appliance must be disposal by the installer / dealer.

ATTENTION!!

Recycling and disposal of the appliance and the accessories must be made as required by regulations.

Procedure for the water flow servomotor installed

This is a series of machine which has water flow servomotor system (water proportional valve), it has a wider adjusting range of water flow, and it works according to the principle as below: power on, CPU reads the water flow and judges if the maximum thermal load of the machine is able to reach the set temperature, if it's negative, it will activate the servomotor to reduce water flow to meet the temperature request of client.

If the motor disassembly is required during maintenance, the following steps should be complied.

1. Mount the water flow servo device in the inlet connector, cover the plate, make the locating bulge upward, ensure the locating bulge inserts through the corresponding hole in the cover plate.

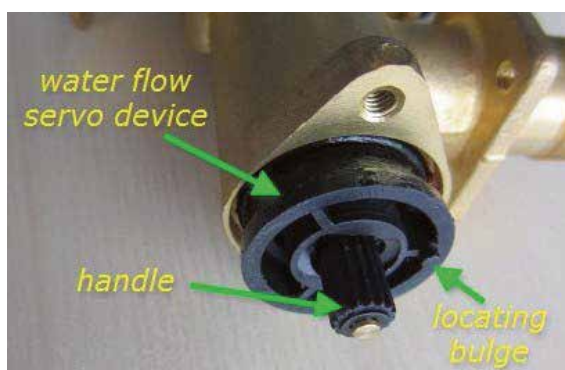

2. Tighten the cover plate screws, then turn the handle of the water flow servo device clockwise to tighten the device till the end.



3. Before assembling the servo moter to the cover plate, connect the servo moter cable with PCB, power on and enter the PCB setting menu, select **LC** to reset the motor at default angle (315°).

4. When the motor rotation is confirmed to be stopped, unplug the electric wire. Slightly mount the motor by aligning 2 locating bulges to the holes of cover plate of servo-device, tighten screws.



TECHNICAL DATA

Technical Data

Model name :		NEXT OUTDOOR			
		11 ZA EVO	16 ZA EVO	20 ZA EVO	24 ZA EVO
Type		D			
Gas category		NG/LPG		NG/LPG	
Maximum nominal heat input	kW	21.5	31.0	40.0	47.0
Minimum nominal heat input	kW	5.0	6.5	9.0	9.0
Maximum nominal heat output	kW	19.5	28.9	36.8	43.3
Minimum nominal heat output	kW	4.5	6.1	8.4	8.4
Domestic hot water temperature maximum	°C	65			
Domestic hot water temperature minimum	°C	35			
D.H.W. Nominal flow rate	l/min	11	16	20	24
D.H.W. minium flow rate	l/min	>2		>3,8	
Water pressure maximum	MPa	0.85			
Water pressure minimum	MPa	0.01			
Flue fumes temperature at Maximum nominal heat input	°C	126	124	135	147
Flue fumes temperature at Minimum nominal heat input	°C	86.0	85.0	95	95
MAX capacity fumes (G20)	g/s	15.71	20.13	30.10	37.40
MIN capacity fumes (G20)	g/s	16.70	22.10	32.60	34.71
Dimensions					
Height		563		582	
Width		350		375	
Depth		130		160	
Power supply voltage/frequency	V/Hz	230 / 50			
Power consumption (without antifreeze heating)	W	37	48	55	60
Power consumption (antifreeze heating device)	W	123			
Internal fuse		2A			
Electric system grades of protection	IP	X5D			
Minimum operating room temperature	°C	-20			
Dry weight	Kg	14.6	15.2	17.6	17.6



WARRANTY PROCEDURE

Herewith a kind reminder to our valued customers of the Ariston/Heat Tech Warranty Procedure.

- 1.) Warranty periods on Ariston/Heat Tech Geysers:
 - 5 Years on Inner Cylinder
 - 1 Year on Electrical (Element & Thermostat)
 - 2 Years on Safety Valve & Drain Cock
- 2.) Please always urge your customers to utilize qualified plumbers to do installations of Ariston/Heat Tech geysers.
- 3.) **Please always inform your customers when selling Ariston/Heat Tech geysers, that they should never remove the geyser from the original installation during the warranty period, as this will automatically void the warranty.** All geysers must remain in position and untampered with, allowing our service agent to inspect the reported problem.
- 4.) **Please never accept the return of a geyser to your store, and please never offer a replacement geyser from the store to the customer.** This would effectively mean that the geyser has been removed from the installation, which voids the warranty, and Ariston/Heat Tech will then not be able to assist either the store, nor the end user customer.
- 5.) Kindly educate your customers to **follow the below warranty procedure** to avoid disputes or misunderstandings in future :
 - a.) After the customer has determined that the problem with the water heater is related to, AND covered under the warranty conditions, the customer has to report the problem DIRECTLY to our Service Centre. All geysers must remain in position and untampered with, allowing our service agent the opportunity to inspect the reported problem.
 - b.) When reporting the problem to our Service Call Centre, the customer or end user will be required to provide the following information:
 - Geyser Serial Number
 - DOM (Date of Manufacturing)
 - Geyser Size
 - Proof of purchase/installation date
 - End Users Name, Surname, Contact Telephone Number(s) & e-mail address
 - Installation Address
 - Merchant Name (i.e. where geyser was purchased)
 - The Problem with the geyser
 - In some cases the end user customer *may* be requested to provide indicative photo(s) of the installation.

c.) Customers can contact the Ariston/Heat Tech After Sales Service Department at:

- Contact Number 1: 079 921 0118
- Contact Number 2: 087 943 7470
- e-mail : service@heattech.co.za
- Operating Hours: Mon to Fri 07:30 to 18:00
- Sat to Sun 07:30 to 15:00

d.) It may be preferable for yourself and/or end user to rather send an e-mail to service@heattech.co.za whereby providing the required information, saving time, and thereby having a record of the reported incident.

e.) The customer will be given a reference number for the incident reported.

f.) Ariston/Heat Tech Service Agent will then contact the end user customer to make the necessary further arrangements.

May we please ask that you distribute to, and advise your relevant staff accordingly.

Kind regards ,

INSTALLATION AND WARRANTY INSTRUCTIONS

IT IS THE RESPONSIBILITY OF THE INSTALLER TO INFORM THE END USER OF THE INSTALLATION, MAINTENANCE & REPAIR REQUIREMENTS FOR THIS WATER HEATER IN ACCORDANCE WITH SANS 10254 AND THE MANUFACTURERS REQUIREMENTS.

INSTALLATION INSTRUCTIONS - PLUMBING TO BE INSTALLED BY A QUALIFIED PLUMBER AND TO COMPLY WITH SANS 10254 & 10252-1 INSTALLER TO ISSUE A PLUMBING CERTIFICATE OF COMPLIANCE

This water heater must be fitted with the supplied TP VALVE before installation. Always fit this water heater with a PRESSURE CONTROL VALVE and EXPANSION CONTROL VALVE (which may be combined in one unit) not exceeding the kPa rating of the water heater as stated on the serial label. TP VALVE and EXPANSION VALVE overflow pipes must be led separately to the outside of the building in a continuous downward direction, in a frost free ambient with the outlets being left open to the atmosphere, and in case of the TP VALVE must be copper. The EXPANSION VALVE is designed to drip under normal operating conditions and must never be plugged.

1. Flush the cold water supply line prior to connecting.
2. Check that the control valve is free from dirt.
3. Ensure all piping and water heater brackets are securely fixed.
4. After connecting the installation, open one or more hot water taps and open the cold water to dispel air from the system.
5. Close all hot taps to bring water heater under pressure.
6. Check all plumbing connections for leaks.
7. Installation diagrams must be complied with in all respects.
8. The installation of a drip tray is required where water leaking from the water heater or connections could cause consequential damage.

INSTALLATION INSTRUCTIONS - ELECTRICAL ELECTRICAL WORK TO BE CARRIED OUT BY A QUALIFIED ELECTRICIAN AND TO COMPLY WITH SANS 10142-1 WARNING: THIS APPLIANCE MUST BE EARTHED & BONDED

1. Heat resisting round 2.5mm² (minimum) 3 core stranded cable should be used to connect the electrical supply.
2. A double pole isolator switch to be installed within 1m of the water heater - correctly rated for the element size.
3. Circuit breaker on distribution board to be correctly rated for the element size.
4. Turn off the circuit breaker on the distribution board as well as the isolator at the water heater.
5. Remove the electrical access panel.
6. Cut away tips of old electrical wire, stripping away the insulation.
7. Connect and tightly secure electrical connection to the thermostat / terminal block. Ensuring thermostat is tightly inserted into the element.
8. Replace electrical access panel.
9. Ensure the water heater is full of water before switching on electricity, even for testing purposes.
10. Heating element will burn out if turned on without water.

INSTALLATION INSTRUCTIONS - WALL MOUNTING

1. Remove brackets from the floor mounting position and bolt to side of the unit in the wall mounting position.
2. Bolt unit to the wall using suitable rated fixation bolts.

NOTE: 200L & 250L UNIT MAY NOT BE WALL MOUNTED

MAINTENANCE INSTRUCTIONS

SWITCH OFF ELECTRICAL SUPPLY BEFORE ATTEMPTING ANY MAINTENANCE OR REPAIRS ON THE WATER HEATER

REPLACEMENT OF THERMOSTAT

1. Disconnect wiring, remove thermostat by pulling it out of its pocket.
2. Fit new thermostat, ensuring the stem of the thermostat is not bent or damaged in any way. On electronic models, ensure that the metallic thermostat bulb is inserted before the wired probe.
3. Reconnect wiring to thermostat ensuring connections are clean, tight and secure.
4. Set thermostat to 60°C or as required by user.

REPLACEMENT OF ELEMENT

1. Drain water from the water heater.
2. Remove thermostat as above and remove flange lid from cylinder.
3. Remove old element and gasket from flange lid.
4. Fit new element and gasket to flange lid.
5. Refit flange lid, and replace thermostat as above.

REPLACEMENT OF ANODE

1. The magnesium anode installed in a vitreous enamel lined steel water heater will slowly dissipate whilst protecting the cylinder.
2. The life of the cylinder may be extended by replacing the anode.
3. Inspect the anode yearly, and if required, replace the anode.
4. Replacement of the anode should be carried out at minimum 2 year intervals, during the warranty period, to ensure protection of the steel cylinder.
5. The life expectancy of the anode would be dependent on the water quality in the area, which the water authority can advise on.
6. A guideline below (as reference only):

TOTAL DISSOLVED SOLIDS PPM	RECOMMENDED REPLACEMENT
0 - 400	3 Years
400 - 600	2 Years
Over 600	1 Year

Fitment of an aluminium anode is recommended for harsh water conditions.

7. When water is supplied from a borehole or well, anodes should be replaced at least once a year.
8. Replace anode as follows:
 - (a) Drain water heater.
 - (b) Remove anode cover and unscrew anode from cylinder.
 - (c) Fit new anode and replace anode cover.

THE ANODE IS A MAINTAINABLE COMPONENT

ALL PIPE WORK AND COMPONENTS CONNECTED TO THE INLET, OUTLET AND T&P VALVE SHOULD BE THERMALLY INSULATED FOR 2 METERS. THE THERMAL INSULATION SHALL COMPLY WITH THE REQUIREMENTS OF SANS 10252-1, SANS 10254, SANS 10400-XA AND SANS 204.

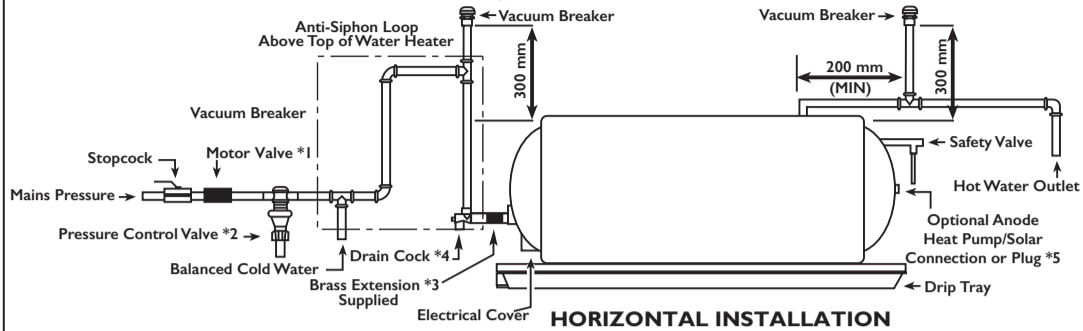

THIS WATER HEATER IS FITTED WITH A MAGNESIUM ANODE THAT REQUIRES PERIODIC REPLACEMENT

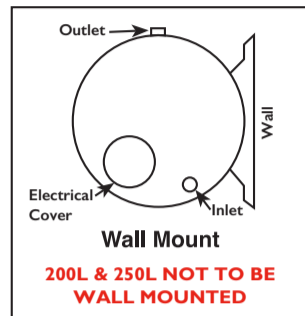

200L & 250L NOT TO BE WALL MOUNTED

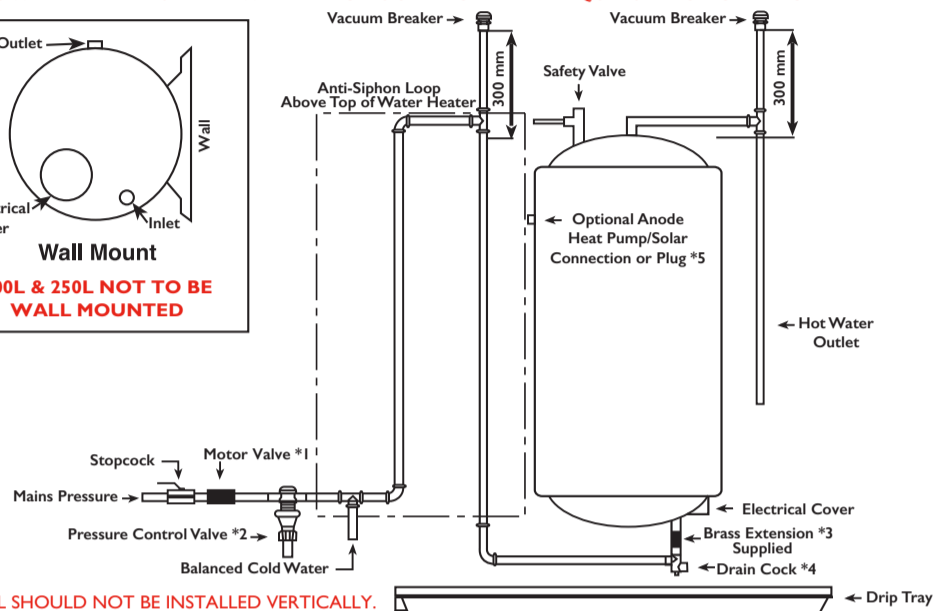

50L & 250L SHOULD NOT BE INSTALLED VERTICALLY.

- *1 Optional extra for certain models only
- *2 Refer to the serial label for the correct pressure rating of the water heater.
- *3 Supplied on certain models only.
- *4 Solar or heat pump compatible when used in conjunction with a dual drain cock.
- *5 When not using the additional socket for solar or heat pump - ENSURE THAT THE SOCKET IS PLUGGED.

The following minimum installation clearance must be allowed for on the electrical side of the water heater in the event of having to remove the element, thermostat or the anodes and 500mm on the opposite side.

50L - 500mm	100L - 700mm	150L - 950mm	200L - 1500mm	250L - 1500mm

WARRANTY *T & C Apply

This water heater is warranted against faulty materials and/or workmanship not withstanding anything to the contrary contained herein. The company will repair or at its own discretion, replace a defective unit or parts inclusive of labour costs during the warranty period. The repaired or replaced part, or water heater, warranty will still be calculated from original date of manufacture, not from the repaired or replacement date.

The period of warranty is calculated from the date of manufacturing as indicated on the serial plate. This is the only warranty given and it expressly excludes all other warranties, expressed or implied by law. The warranty expressly covers the water heater only and does NOT cover any other part or parts of the installation which may, because of the failure or defect of the water heater become damaged in any way whatsoever and under no circumstances shall the manufacturer be liable for any direct, indirect or consequential loss suffered by the consumer and/or third party.

The warranty is subjected to the following:

- (a) The water heater is installed in accordance with SANS 10142-1: (Electrical) and SANS 10254 & 10252-1 (Plumbing) and in accordance with any other applicable national and local regulations.
- (b) The water heater is installed according to the manufacturers installation requirements.
- (c) The water heater is maintained and serviced yearly.
- (d) The anode is inspected yearly and replaced at least every second year for municipal water supplies.
- (e) The serial plate is not damaged or tampered with in any way.
- (f) The water heater is subjected to normal use with municipal water supply and proper installation by qualified personnel.
- (g) This warranty will exclude any failure due to hard water conditions.
- (h) Elements burnt out due to no water, or element and thermostat terminals burnt / melted are excluded from this warranty.
- (i) The above warranty is subject to only genuine replacement parts being used whilst the inner cylinder is still under warranty.
- (j) The above warranty shall however be completely invalidated if any repairs are effected by the customer or others on his behalf in an attempt, to remedy the alleged fault.
- (k) Under no circumstances must the unit be removed from the installation.
- (l) Sufficient access to the water heater for either repairs or replacement is the responsibility of the end user. The manufacturer will not make good or reassemble any ceilings or cupboards.
- (m) As per SANS 10254, no one-way valve or stop cock allowed between the water heater and expansion relief valve.



HEATTECH

Manufactured by: HEAT TECH GEYSERS (PTY) LTD
294 Barolong Street, Sunderland Ridge
Tel: 087 943 7471

Email: info@heattech.co.za
Web: www.heattech.co.za

WARRANTY PERIODS *T & C apply

Cylinder	5 Years
Electrical Components	1 Year
Gaskets	1 Year
Drain Cock and T&P Valve	2 Years
Anode (consumable, service required)	None

After-Sales Service: 087 943 7470 / service@heattech.co.za