

# ROCKWORTH

CONFIDENCE AT WORK

**AO630/308-3**

**3HP • 100L**

**AIR COMPRESSOR**



Always Read Instruction Manual  
Retain for Future Reference

---

## Warranty

This product has been manufactured to a high quality standard. It is guaranteed against faulty materials and workmanship for 12 months from the date of purchase. Please retain your receipt as proof of purchase.

If the product is found to be defective within the relevant time period, we will either replace all defective parts or, at our discretion, replace the unit free of charge with the same item or items of a greater value and/or specification.

This guarantee does not cover defects caused by or resulting from: misuse, abuse or neglect; lack of maintenance; trade, professional or hire use; repairs attempted by anyone other than our authorised service agent; or damage caused by foreign objects, substances or accident.

## SPECIFICATIONS

ITEM	DATA
Power	2.2Kw(3HP)
Voltage	230V
Frequency	50Hz
Rated Speed	2850 r/min
Current	12 Amp
Delivery	292 L/Min
Discharge Pressure	115PSI/8 Bar
Tank Capacity	100 L
Air Outlet Size	1/4" BSP



## GENERAL SAFETY INSTRUCTIONS

Before attempting to operate this compressor the following basic safety precautions should always be taken to reduce the risk of fire, electric shock and personal injury. It is important to read the instruction manual to understand the application, limitations and potential hazards associated with any tool. They are designed for the safety of yourself and others, ensuring a long and trouble free service life from your machine.

### SAFE OPERATION

#### Work Area

Workbenches should be kept tidy because cluttered benches and work areas invite accidents. Floors should be kept clean and free from rubbish. Special care should be taken if the floor is slippery due to sawdust or wax.

#### Work Environment

Keep the work area well lit. Do not use compressor in areas where there is a risk of explosion or fire from combustible materials, flammable liquids, e.g., paint, varnish, petrol etc or flammable gases and dust of an explosive nature.

#### Guard Against Electric Shock

Do not expose your compressor to rain, or use in damp or wet locations.

#### Beware Children and Pets

Children and pets should be kept out of the work area.

#### Use the right tool

Select the right tool for the job. Do not use a tool for a job for which it was not designed. Do not force a small tool to do the job of a heavy-duty tool.

#### Personal safety Clothing

Do not wear loose clothing, jewellery or anything that could get caught in moving machinery.

#### Hair

Long hair should be tied back or contained in a protective covering.

#### Eye Protection

All ways use protective safety goggles or safety glasses.

#### Ear Protection

Ear protection is advised during periods of extended operation.

#### Footwear

Where there is a risk of heavy objects damaging feet or if there is a risk of slipping on wet or slippery floors suitable non-slip safety footwear should be worn.

#### Secure the Work Piece

Wherever possible secure the work piece using clamps or a vice. It is safer than using your hand and leaves both hands free to control the air tool.

#### Do Not Over-reach

Do not over-reach, keep proper footing and maintain your balance at all times.

#### Maintain Tools with Care

Keep cutting tools sharp and clean for better and safer performance. Follow the instructions for lubricating and changing accessories. Check the tool power cord periodically and if dam-



## GENERAL SAFETY INSTRUCTIONS .....cont

aged have it replaced by an authorised service facility. Keep handles dry, clean and free from oil and grease. Ensure that ventilation slots are kept clean and free from dust at all times. Blocked ventilation slots can cause overheating and damage to the motor.

### Stay Alert

Watch what you are doing, use common sense, and do not operate the air tool when you are tired or have taken medication that causes drowsiness, consumed alcohol or drugs.

### General Warnings for compressors

- Do not attempt to modify the compressor in any way.
- The use of any tools or accessory other than those designed for use with compressed air could result in injury to the operator.
- The output pressure of the compressor should be adjusted to the design pressure of the air tool or accessory being used.
- Always check that the output of the compressor does not exceed the maximum pressure for any attached tool or accessory.
- Repairs should only be carried out by qualified persons using original spare parts. Failure to do so may result in considerable danger to the user.

### Breathable Air Warning

This compressor/pump is not equipped and should not be used to supply breathing quality air for any application of air for human consumption.

**Overload protection.** This compressor is fitted with an overload protection device. In the event that the motor becomes too hot, a thermal protection device will cut the mains supply to the motor. When the motor temperature returns to normal you can reset it by pushing the button on top of the unit.

### Extension Cords and Reels

In general, it is not recommended to use an extension lead. A longer air line is recommended as voltage drop on extension leads may lead to motor damage and will void warranty. If an extension cord must be used, for lengths up to 5 metres, an approved 15amp rated cord must be used.

### Do Not Abuse the Power Cord

Never yank or pull on the power cord to disconnect it from the mains supply socket. Never carry or drag your compressor by its power cord. Keep the power cord away from heat, oil, solvents and sharp edges. If the power cord becomes damaged have it replaced by an authorised service facility.

### Check Damaged Parts

Before using the compressor it should be carefully checked to determine that it will operate prop-





## GENERAL SAFETY INSTRUCTIONS .....cont

erly and perform its intended function. Check for the correct alignment of moving parts ensuring they do not bind. Check for broken or missing parts and have them replaced or repaired at an authorised service centre. Check any other condition that may affect the operation of the compressor. A guard or any other part of the compressor that is damaged should be properly repaired or replaced by an authorised service centre.

### **Disconnect Compressor**

Ensure that the compressor is disconnected from the mains supply and the tank is empty when not in use, before servicing, lubricating or making adjustments to air lines when changing accessories such as blades, bits, nails and cutters on air tools .

### **Avoid Unintentional Starting**

Ensure that the switch is in the OFF position before plugging the compressor into the mains supply

### **Turning the compressor ON and OFF**

Use the red knob on top of the pressure switch to turn the unit on and off. Pull the knob up to turn the compressor on and push the knob in to turn it off. Turning the unit on and off from the mains supply only will result in damage to the motor and void warranty as the pressure switch has an additional function to purge the air trapped in the delivery pipe when the motor is turned off. This minimises the load on the motor when it is next started.



---

# GENERAL VIEW AND MAIN COMPONENTS



1. Main compressor
2. Pressure switch
3. Outlet Valve
4. Pressure gauge
5. Non-Return Valve
6. Drain cock
7. Wheel
8. Discharge pipe
9. Air tank
10. Safety valve
11. Oil Breather
12. Sight Glass
13. Air Filter
14. Motor reset

**Note:** Fittings may differ from those shown above.

---

# Assembly

This air compressor requires some minor assemble before it can be used.

Locate the accessory pack. It should contain :

1. Wheels and hardware set
2. Rubber stoppers
3. Air Filters
4. Oil Breather plug

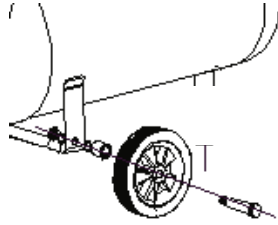

- Fit the wheels to the unit using the washers and bolts provided and fasten the rubber stoppers on to the frame underneath the tank
- Remove the dust plugs from the cylinder heads and fit the air filters to cylinder heads of the compressor.
- Locate the plastic dust plug in the oil filler hole and remove it to expose the oil filler hole.

**Oil Warning :** This unit is shipped with oil in the compressor pump.

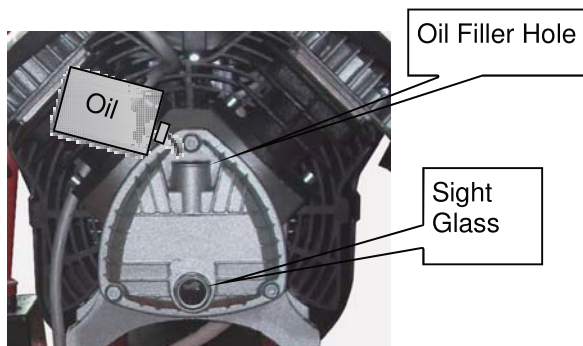

- Add oil if the it is below the center of red circle in the sight glass.

- Check that the small hole in the top of the breather pipe is clear and then insert it into the oil filler hole.

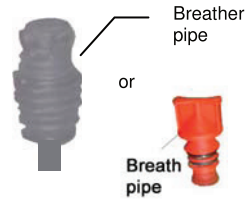

**NOTE:** The oil must be changed after the first 10 hrs of operation then every 20 hrs thereafter.  
**Recommend compressor oil: Use SAE30 for temperatures over 10°C and use SAE10 below 10°C.**

## INITIAL STARTUP

- Ensure the unit is stable in a well-ventilated dry position.
- Ensure that drain the valve is closed and air outlets are closed.  
Connect the power lead to the mains.
- Start the compressor by pulling on the red knob.
- Check for air leaks
- To turn the unit off push the red knob

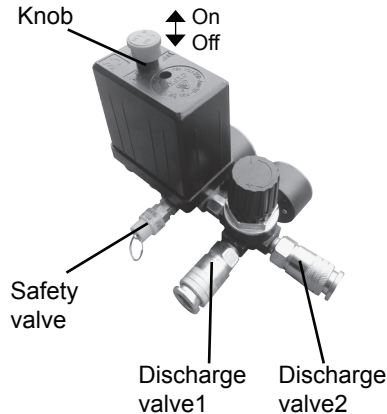

**Note:** Output fittings may differ from those shown above.

**Warning:** Use the red knob to turn the unit on and off, not the mains switch. Turning the unit on and off from the mains only will result in damage to the motor

## Operation

The pressure in the tank is controlled by the action of the pressure switch located under the pressure switch cover

When the set maximum pressure is reached the pressure switch activates and the motor is turned off. The pressure will then decrease as the air is used until the set minimum is reached after which the pressure switch turns the motor to on again.

The operator of the compressor should be well aware that during use of the compressor the motor will cycle (start and stop) under the influence of the rising or falling pressure in the tank and the motor will start without any warning.

The maximum and minimum pressures are factory set and should not be altered.

The pressure of the regulated outlet can be changed by turning the control knob. Rotate the knob clockwise to increase pressure and anti-clockwise to decrease

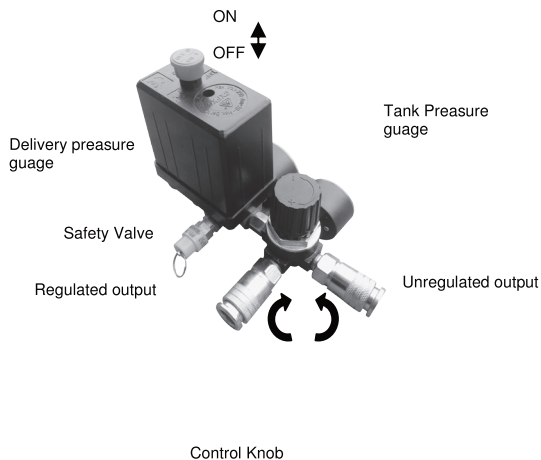

**Note:** Output fittings may differ from those shown

---

# MAINTENANCE

**Warning:** Before maintenance operation, stop the air compressor, disconnect the unit from the mains supply and discharge all air in the air tank.

## Daily

1. Check oil level before each use.
2. Drain the condensation from the air receiver.
3. Check for air leaks.

## Weekly

1. Remove air filter element and clean or replace as required.

## Monthly

1. Inspect non-return valve (clean or replace as required)
- Caution:** ensure That air the tank is empty for this operation.
2. Manually test the safety valve by pulling the ring.

## Three Monthly

1. Change Oil
2. Tighten cylinder head bolts.
3. Clean and check valve assembly, replace gaskets/ valves if worn or damaged.

**Recommend compressor oil use SAE30 for temperatures over 10°C and use SAE10 below 10°C.**

<b>TROUBLES AND REMEDIES</b>		
<b>Trouble</b>	<b>Possible causes</b>	<b>Remedies</b>
Motor unable to run or running slow	(1) Fault in line, or voltage insufficient (2) Power wire too thin or too long (3) Fault in pressure switch (4) Fault in motor (5) Sticking of main compressor	(1) Check the line (2) Replace the wire (3) Repair or replace (4) Repair or replace (5) Check and repair
Sticking of main compressor	(1) Moving parts burnt due to the oil insufficient (2) Moving parts damaged, or stuck by foreign body	Check crankshaft, bearing, connecting rod, piston, piston ring, etc. and replace if necessary
Excessive vibration or abnormal noise	(1) Connecting part loosed (2) Foreign body got into main compressor (3) Piston knocking valve seat (4) Moving parts seriously worn	(1) Check and retighten (2) Check and clean away (3) Replace with thicker paper gasket (4) Repair or replace
Pressure insufficient or discharge capacity decreased	(1) Motor running too slow (2) Air filter choked up (3) Leakage of safety valve (4) Leakage of discharge pipe (5) Sealing gasket damaged (6) Valve plate damaged, carbon buildup or stuck (7) Piston ring and cylinder worn or damaged	(1) Check and remedy (2) Clean or replace the cartridge (3) Check and adjust (4) Check and repair (5) Check and replace (6) Replace and clean (7) Repair or replace
Excessive oil consumption	(1) Oil level too high (2) Breath pipe choked up (3) Piston ring and cylinder worn or damaged	(1) Keep the level within set range (2) Check and clean (3) Repair or replace

**SYMBOLS**



Before use, read the handbook carefully



Warning, hot surfaces



Obligatory eye protection



Danger - automatic control (closed loop)



Dangerous voltage



Pumping unit



Power



Tank capacity



Air intake



Absorbed current



Max. pressure



Revolutions / min. (rpm)



Voltage and frequency



Weight

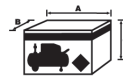

Package overall dimensions



Oil amount



Power cable cross section



# Electrical Schematic

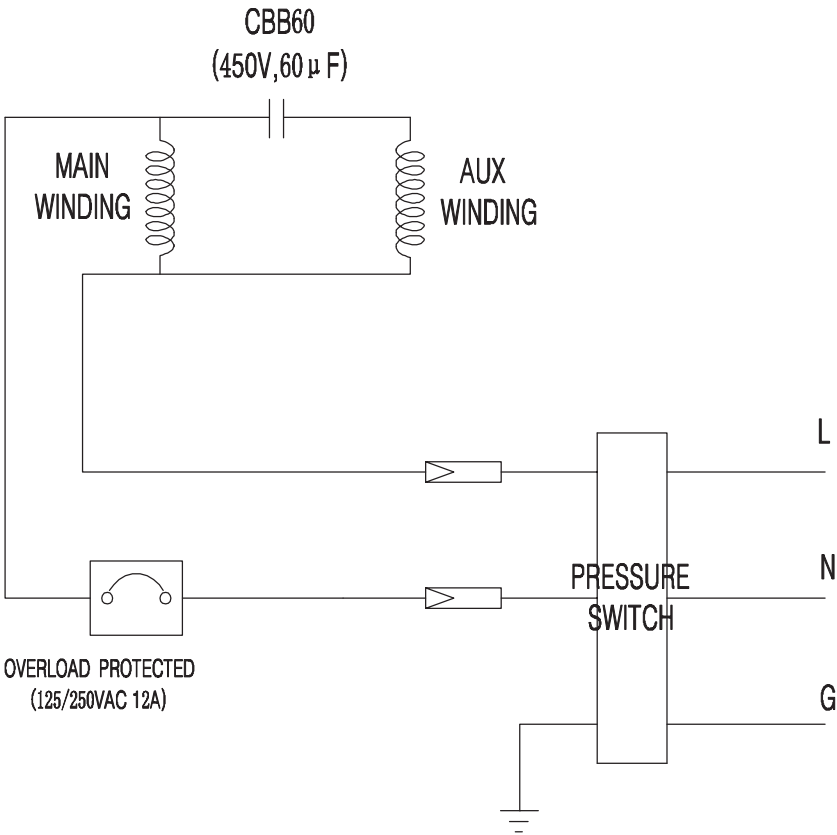

## **Warranty Information**

Rockworth products have a limited warranty against defects in material and workmanship from the date of purchase. Rockworth products are designed for Domestic/Light Industrial use and the warranty does not apply to defects resulting from accidental damage, improper use, or exceeding the design limits of the product.

Please take time to read the instruction manual provided. For more information on the range, please visit [www.rockworthproducts.co.za](http://www.rockworthproducts.co.za)

Rockworth is exclusively manufactured for and distributed by Agrinet (Pty) Ltd.

Private Bag x165, Centurion, 0046

T: +27(0) 12 657 2222

E: [enquiries@agrinet.co.za](mailto:enquiries@agrinet.co.za)