

Technical data

SN2F50-250-E-OB-TB-GH

MEI >= 0,4

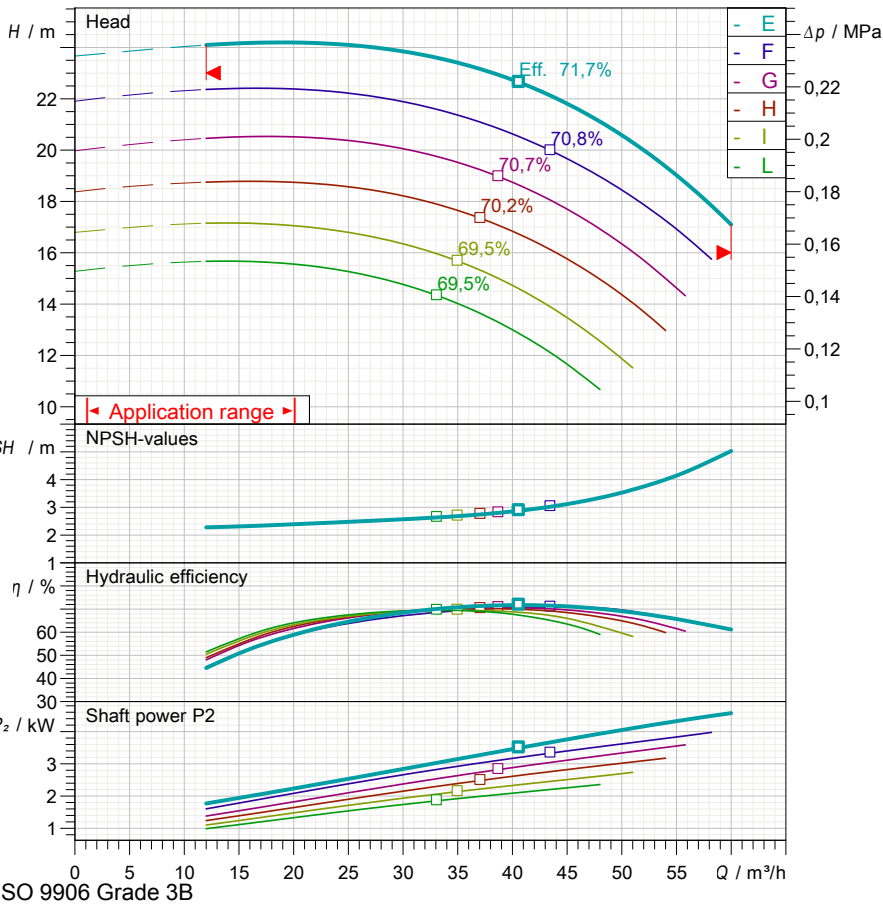

Operating data specification	
Capacity	
Head	
Fluid	Pure water
Type of installation	<Single head pump>

Pump operating data	
Design	SN2F50-250-E-OB-TB-GH
Impeller Ø	260 mm
Speed	1450 1/min
Flow	
Head	
Shaft power P2	
Efficiency	
Head (Q=0)	23,7 m
Non return valve loss	

Electric motor technical data	
Design	
Rated power	
Frequency	
Number of poles	
Nominal speed	
Rated voltage	
Starting mode	
Rated current	
Insulation class	
Degree of protection	

Use limits	
Max N° startings/hour	
Max. runing time with Q=0	2 min
Max. solids contents	60 g/m³
Max. pumped liquid temperature	90 °C
Maximum density	998 kg/m³
Maximum viscosity	1 mm²/s

Materials	
Pump body	Cast iron
Impeller	Cast iron + cataphoresis
Wear ring	Cast iron
Support	Cast iron
Bearing support	Cast iron
Shaft	Stainless steel
Twiner system®	Stainless steel
Stuffing-box packing	Synthetic fibers
Shaft protection bushing	Chromed stainless steel

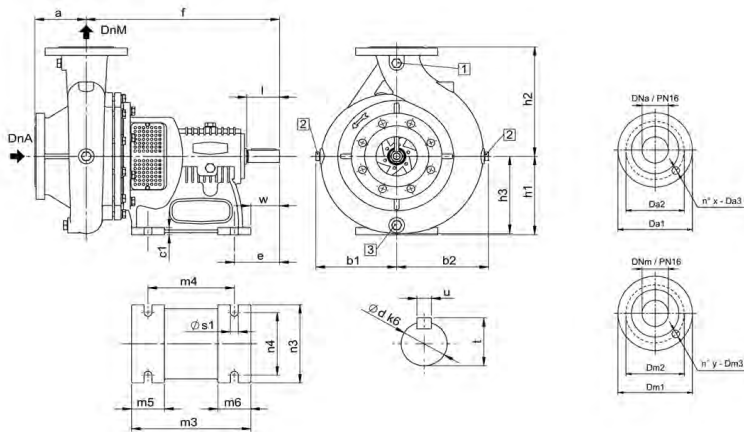

Dimensions in				mm				Total weight				61 kg			
DNa	65	h2	225	s1	14	2	G 1/4"	x	4						
DNm	50	h3	174	e	80	3	G 3/8"	y	4						
a	100	m3	230	w	45	Da1	185								
b1	169	m4	160	d	24	Da2	145								
b2	182	m5	70	l	50	Da3	18								
c1	16	m6	70	u	8	Dm1	165								
f	360	n3	160	t	26	Dm2	125								
h1	160	n4	125	1	G 1/4"	Dm3	18								

Performance curves

SN2F50-250-E-OB-TB-GH

MEI $\geq 0,4$

Performances

Speed	1450 1/min	Density	998 kg/m ³
Flow	Min. 12 m ³ /h	Viscosity	1 mm ² /s
	Max. 60 m ³ /h	Temperature	20 °C
Efficiency	Max. 40,6 m ³ /h	Tolerances	ISO 9906 Grade 3B

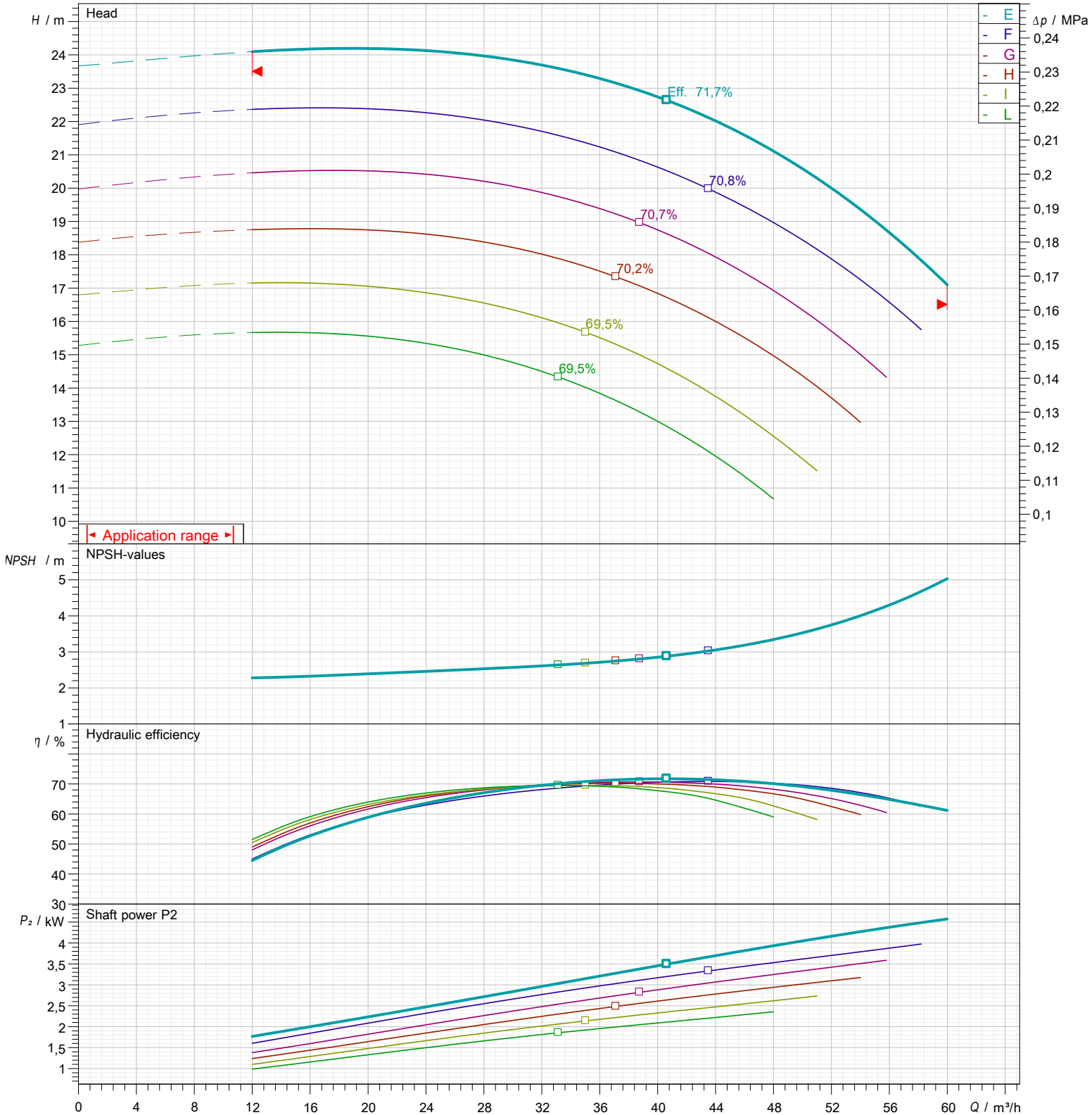

Types of installation

SN2F50-250-E-OB-TB-GH

MEI $\geq 0,4$

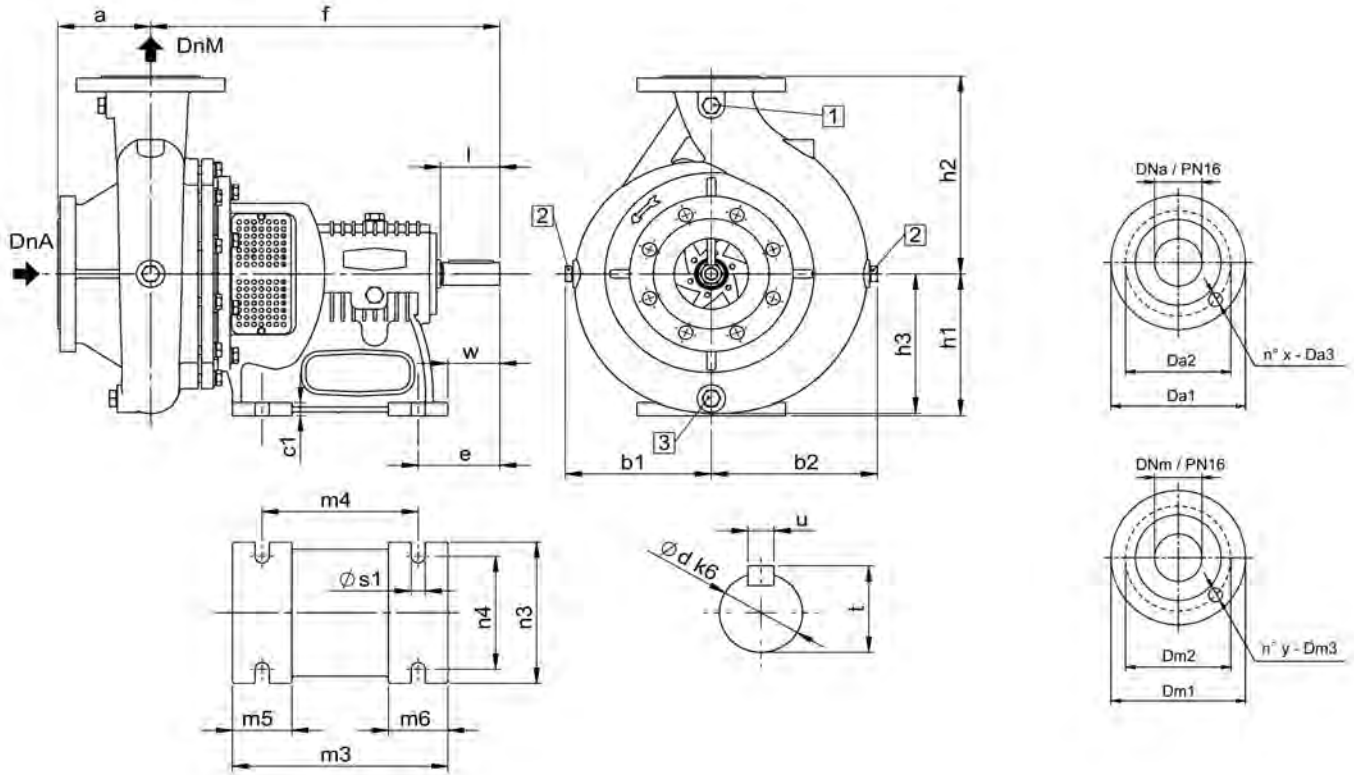

Dimensions in		mm	Total weight	61 kg
DNa	65	u	8	
DNm	50	t	26	
a	100	1	G 1/4"	
b1	169	2	G 1/4"	
b2	182	3	G 3/8"	
c1	16	Da1	185	
f	360	Da2	145	
h1	160	Da3	18	
h2	225	Dm1	165	
h3	174	Dm2	125	
m3	230	Dm3	18	
m4	160	x	4	
m5	70	y	4	
m6	70			
n3	160			
n4	125			
s1	14			
e	80			
w	45			
d	24			
l	50			

Technical data

SN2F50-250-E-OB-TB-GH

MEI >= 0,4

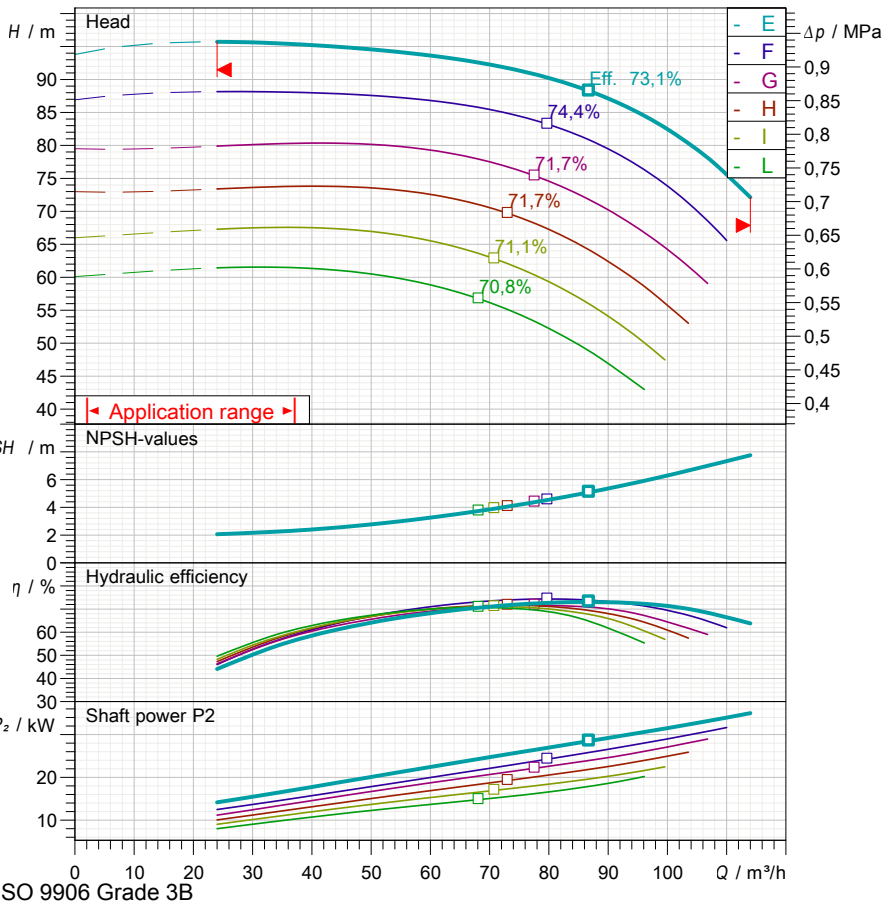

Operating data specification	
Capacity	
Head	
Fluid	Pure water
Type of installation	<Single head pump>

Pump operating data	
Design	SN2F50-250-E-OB-TB-GH
Impeller Ø	260 mm
Speed	2900 1/min
Flow	
Head	
Shaft power P2	
Efficiency	
Head (Q=0)	93,8 m
Non return valve loss	

Electric motor technical data	
Design	
Rated power	
Frequency	
Number of poles	
Nominal speed	
Rated voltage	
Starting mode	
Rated current	
Insulation class	
Degree of protection	

Use limits	
Max N° startings/hour	
Max. runing time with Q=0	2 min
Max. solids contents	60 g/m³
Max. pumped liquid temperature	90 °C
Maximum density	998 kg/m³
Maximum viscosity	1 mm²/s

Materials	
Pump body	Cast iron
Impeller	Cast iron + cataphoresis
Wear ring	Cast iron
Support	Cast iron
Bearing support	Cast iron
Shaft	Stainless steel
Twiner system®	Stainless steel
Stuffing-box packing	Synthetic fibers
Shaft protection bushing	Chromed stainless steel

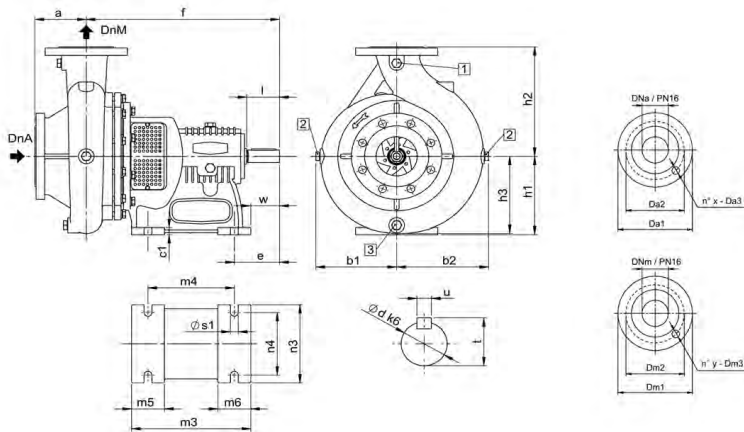

Dimensions in				mm				Total weight				61 kg			
DNa	65	h2	225	s1	14	2	G 1/4"	x	4						
DNm	50	h3	174	e	80	3	G 3/8"	y	4						
a	100	m3	230	w	45	Da1	185								
b1	169	m4	160	d	24	Da2	145								
b2	182	m5	70	l	50	Da3	18								
c1	16	m6	70	u	8	Dm1	165								
f	360	n3	160	t	26	Dm2	125								
h1	160	n4	125	1	G 1/4"	Dm3	18								

Performance curves

SN2F50-250-E-OB-TB-GH

MEI $\geq 0,4$

Performances

Speed	2900 1/min	Density	998 kg/m ³
Flow	Min. 24 m ³ /h	Viscosity	1 mm ² /s
	Max. 114 m ³ /h	Temperature	20 °C
Efficiency	Max. 86,8 m ³ /h	Tolerances	ISO 9906 Grade 3B

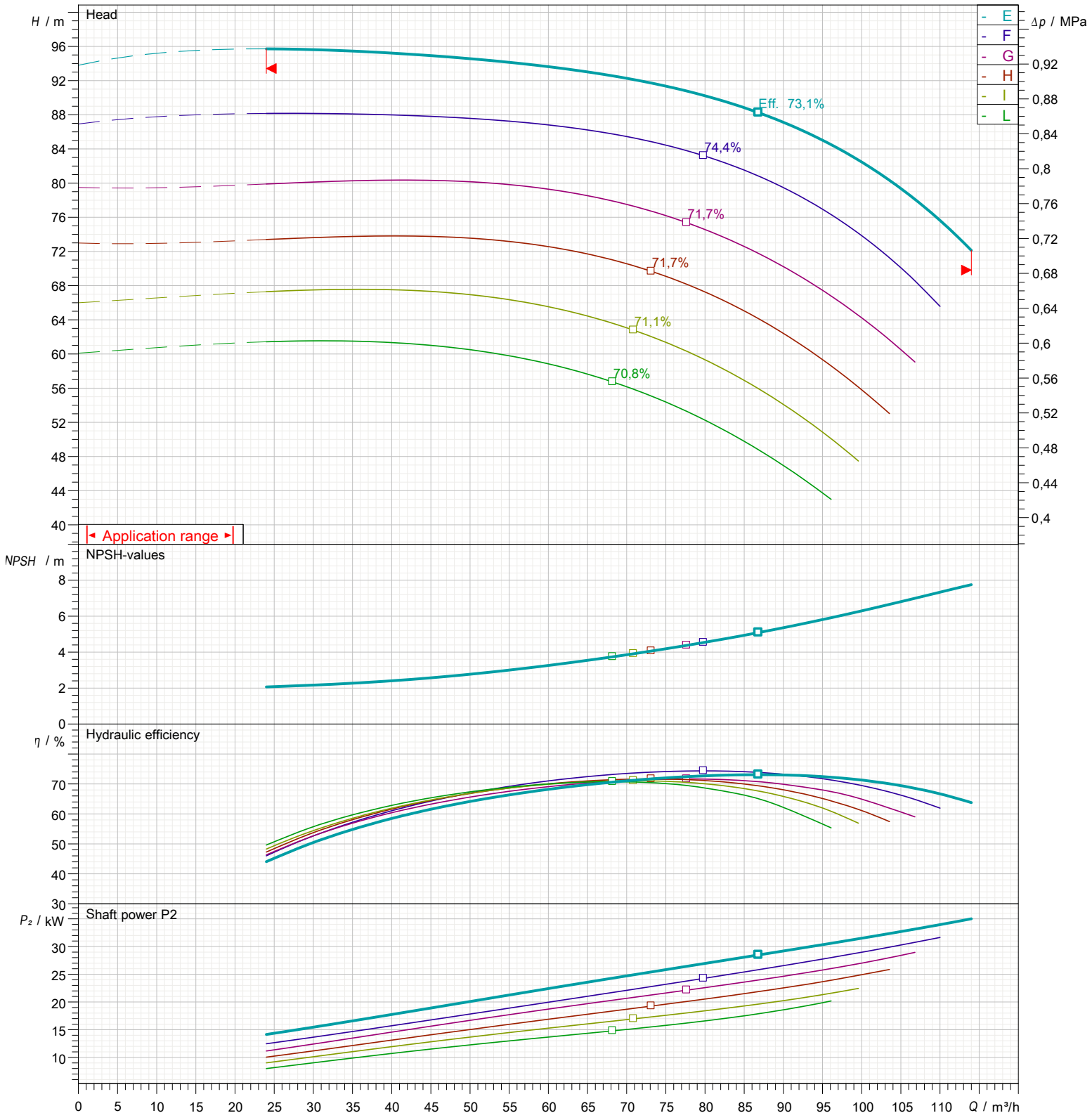

Types of installation

SN2F50-250-E-OB-TB-GH

MEI >= 0,4

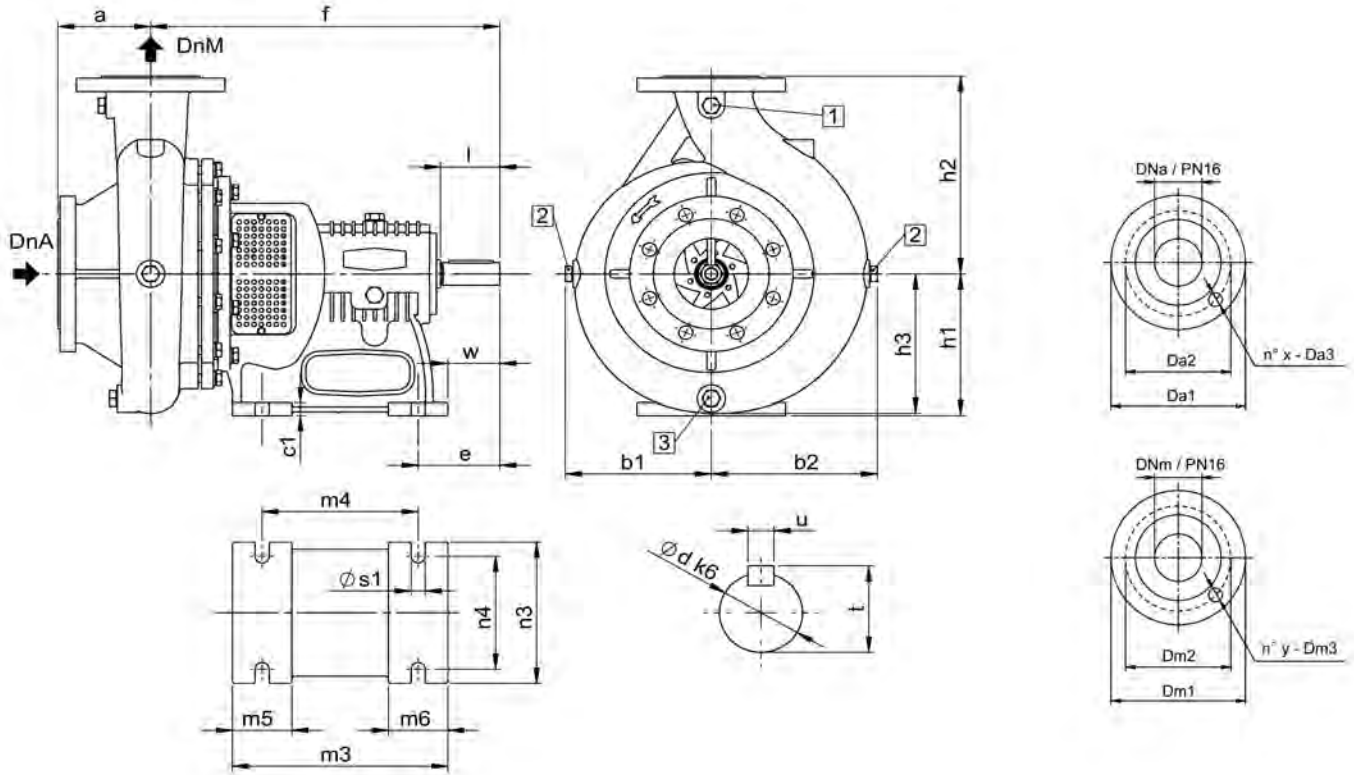

Dimensions in		mm	Total weight	61 kg
DNa	65	u	8	
DNm	50	t	26	
a	100	1	G 1/4"	
b1	169	2	G 1/4"	
b2	182	3	G 3/8"	
c1	16	Da1	185	
f	360	Da2	145	
h1	160	Da3	18	
h2	225	Dm1	165	
h3	174	Dm2	125	
m3	230	Dm3	18	
m4	160	x	4	
m5	70	y	4	
m6	70			
n3	160			
n4	125			
s1	14			
e	80			
w	45			
d	24			
l	50			

rovatti pompe

Products you can rely on

Rovatti cataphoresis coating

Cataphoresis is an electrochemical coating process for cast iron components provided by Rovatti Pompe to improve protection from weather conditions, alkali and diluted acids.

Rovatti cataphoresis treatment is characterized by a high adhesion to the surfaces and uniformity of the coating also in the inner cavities of the component.

The result is a black semi-gloss protective layer with homogeneous thickness.

Rovatti cataphoresis treatment produces a reduced surface friction in the hydraulic channels improving pump efficiency and increasing driving motor life.

Components treated with the Rovatti cataphoresis coating are easily removable during the usual maintenance operations.



HEADQUARTERS:
42042 FABBRICO (REGGIO EMILIA)
ITALY
Tel +39 0522 66 50 00
Fax +39 0522 66 50 20
info@rovatti.it
www.rovatti.it

2000 DIVISION:
42047 ROLO (REGGIO EMILIA)
ITALY
Tel +39 0522 66 72 17 / 0522 66 72 25
Fax +39 0522 66 09 79
info@rovatti.it
www.rovatti.it

IPERSOM DIVISION:
42042 FABBRICO (REGGIO EMILIA)
ITALY
Tel +39 0522 66 08 15
Fax +39 0522 66 02 70
info@rovatti.it
www.rovatti.it



rovatti pompe

Products you can rely on

Twinner System®

To make maintenance operation more efficient, it is essential to reduce the time and the cost of any intervention. The exclusive Twinner System® by Rovatti allows to easily operate on gland packing box without removing shaft support.



Available on many pumps of the wide Rovatti production range the Twinner System® consists of:

- Flange in two stainless steel halves that through a simple extraction greatly facilitates the replacing operations of stuffing-box packing.
- Easy to adjust and long-term functioning stuffing-box packing on stainless steel chromium coated bush.
- Stainless steel screws that allow easy disassembling, control and stuffing-box replacement procedures even after several operation hours.



HEADQUARTERS:
42042 FABBRICO (REGGIO EMILIA)
ITALY
Tel +39 0522 66 50 00
Fax +39 0522 66 50 20
info@rovatti.it
www.rovatti.it

2000 DIVISION:
42047 ROLO (REGGIO EMILIA)
ITALY
Tel +39 0522 66 72 17 / 0522 66 72 25
Fax +39 0522 66 09 79
info@rovatti.it
www.rovatti.it

IPERSOM DIVISION:
42042 FABBRICO (REGGIO EMILIA)
ITALY
Tel +39 0522 66 08 15
Fax +39 0522 66 02 70
info@rovatti.it
www.rovatti.it

