

Technical data

SN3F100-250-E-OB-TB-GG

MEI >= 0,4

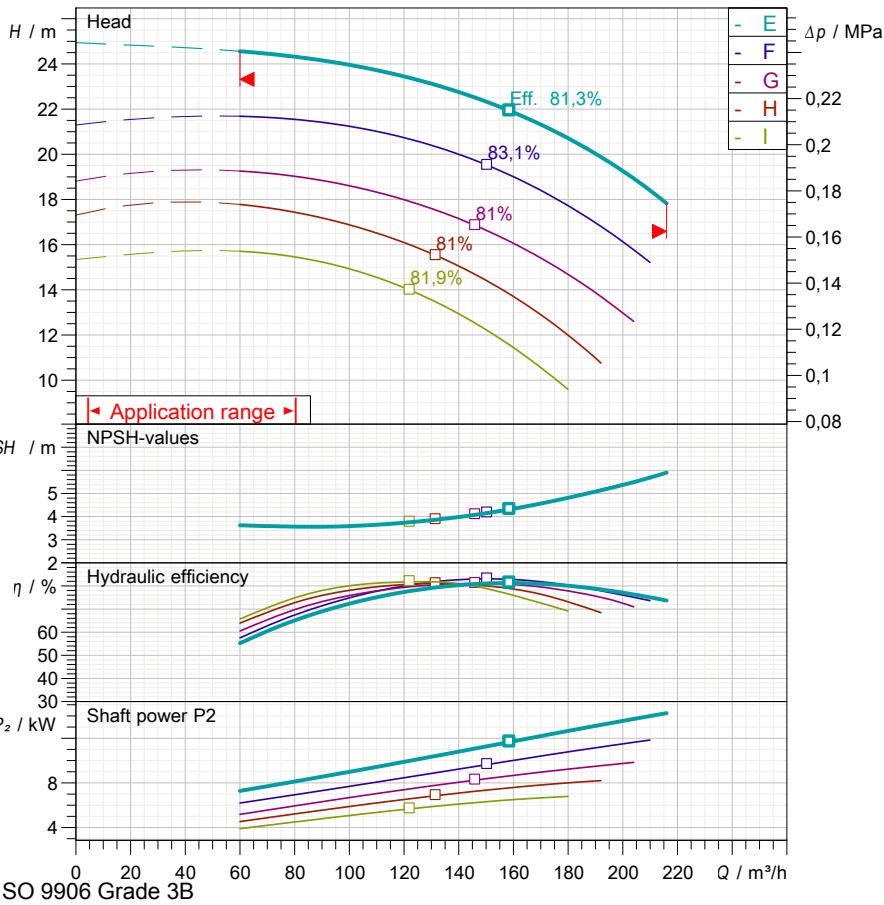

Operating data specification	
Capacity	
Head	
Fluid	Pure water
Type of installation	<Single head pump>

Pump operating data	
Design	SN3F100-250-E-OB-TB-GG
Impeller Ø	270 mm
Speed	1450 1/min
Flow	
Head	
Shaft power P2	
Efficiency	
Head (Q=0)	24,9 m
Non return valve loss	

Electric motor technical data	
Design	
Rated power	
Frequency	
Number of poles	
Nominal speed	
Rated voltage	
Starting mode	
Rated current	
Insulation class	
Degree of protection	

Use limits	
Max N° startings/hour	
Max. runing time with Q=0	2 min
Max. solids contents	60 g/m³
Max. pumped liquid temperature	90 °C
Maximum density	998 kg/m³
Maximum viscosity	1 mm²/s

Materials	
Pump body	Cast iron
Impeller	Carbon steel + Cataphoresis
Wear ring	Cast iron
Support	Cast iron
Bearing support	Cast iron
Shaft	Stainless steel
Twiner system®	Stainless steel
Stuffing-box packing	Synthetic fibers
Shaft protection bushing	Chromed stainless steel

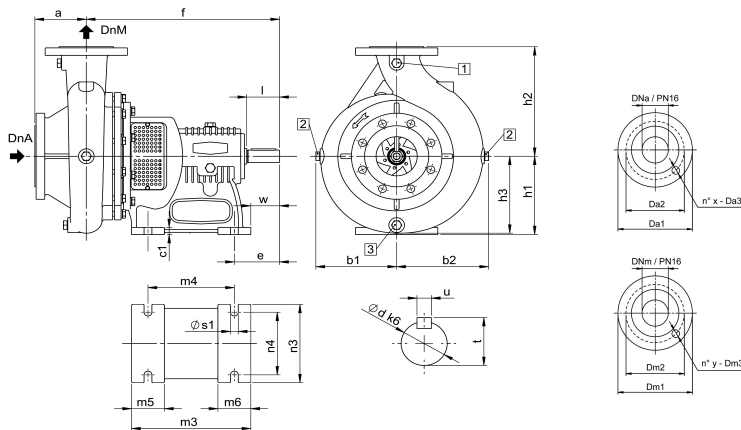

Dimensions in mm				Total weight 96 kg					
DNa	125	h2	280	s1	19	2	G 1/4"	x	8
DNm	100	h3	211	e	110	3	G 1/4"	y	8
a	140	m3	290	w	70	Da1	250		
b1	195	m4	210	d	32	Da2	210		
b2	226	m5	80	l	80	Da3	18		
c1	18	m6	80	u	10	Dm1	220		
f	470	n3	200	t	35	Dm2	180		
h1	200	n4	160	1	G 1/4"	Dm3	18		

Performance curves

SN3F100-250-E-OB-TB-GG

MEI >= 0,4

Performances

Speed	1450 1/min	Density	998 kg/m ³
Flow	Min. 60 m ³ /h	Viscosity	1 mm ² /s
	Max. 216 m ³ /h	Temperature	20 °C
Efficiency	Max. 159 m ³ /h	Tolerances	ISO 9906 Grade 3B

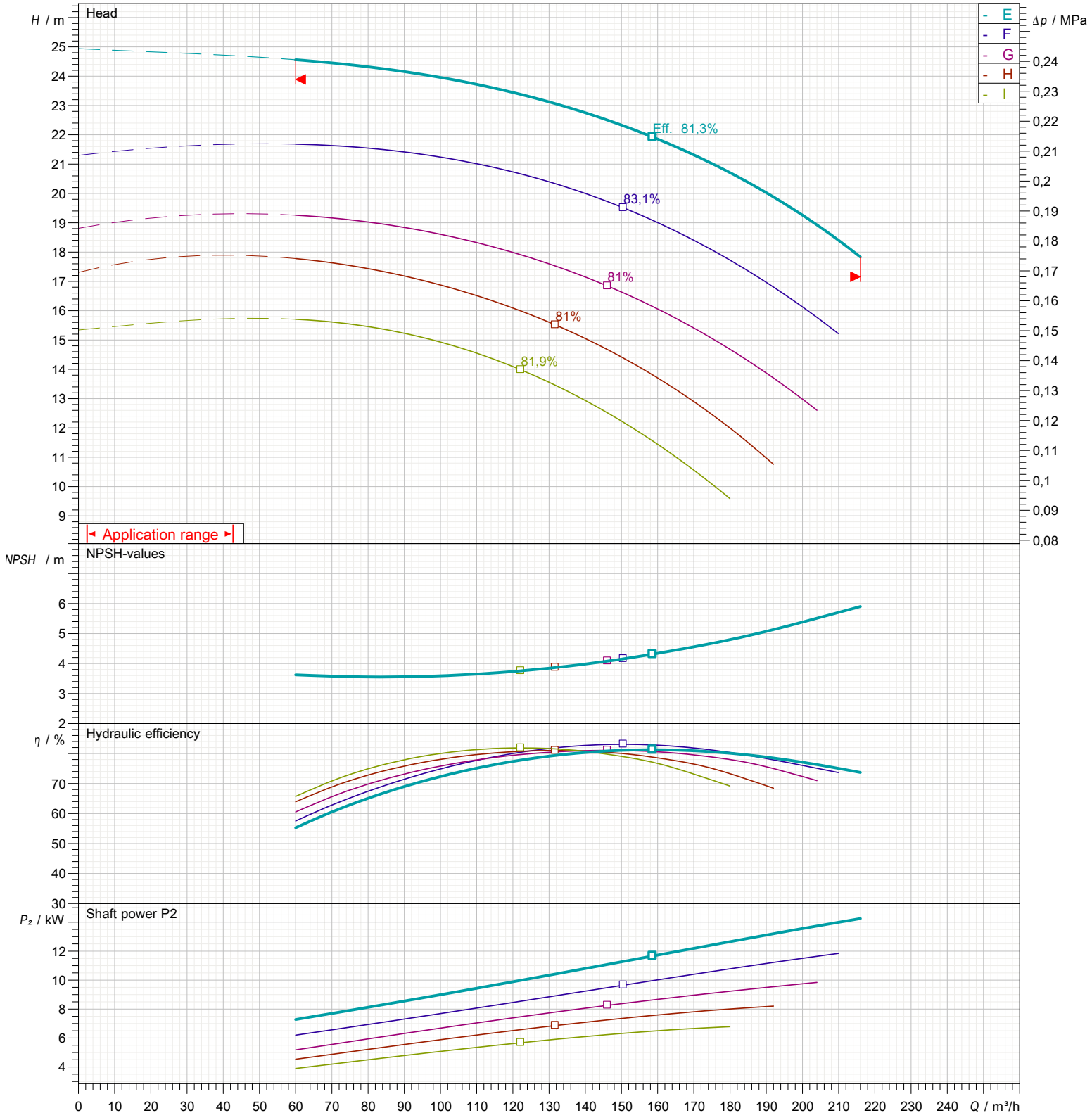

Types of installation

SN3F100-250-E-OB-TB-GG

MEI >= 0,4

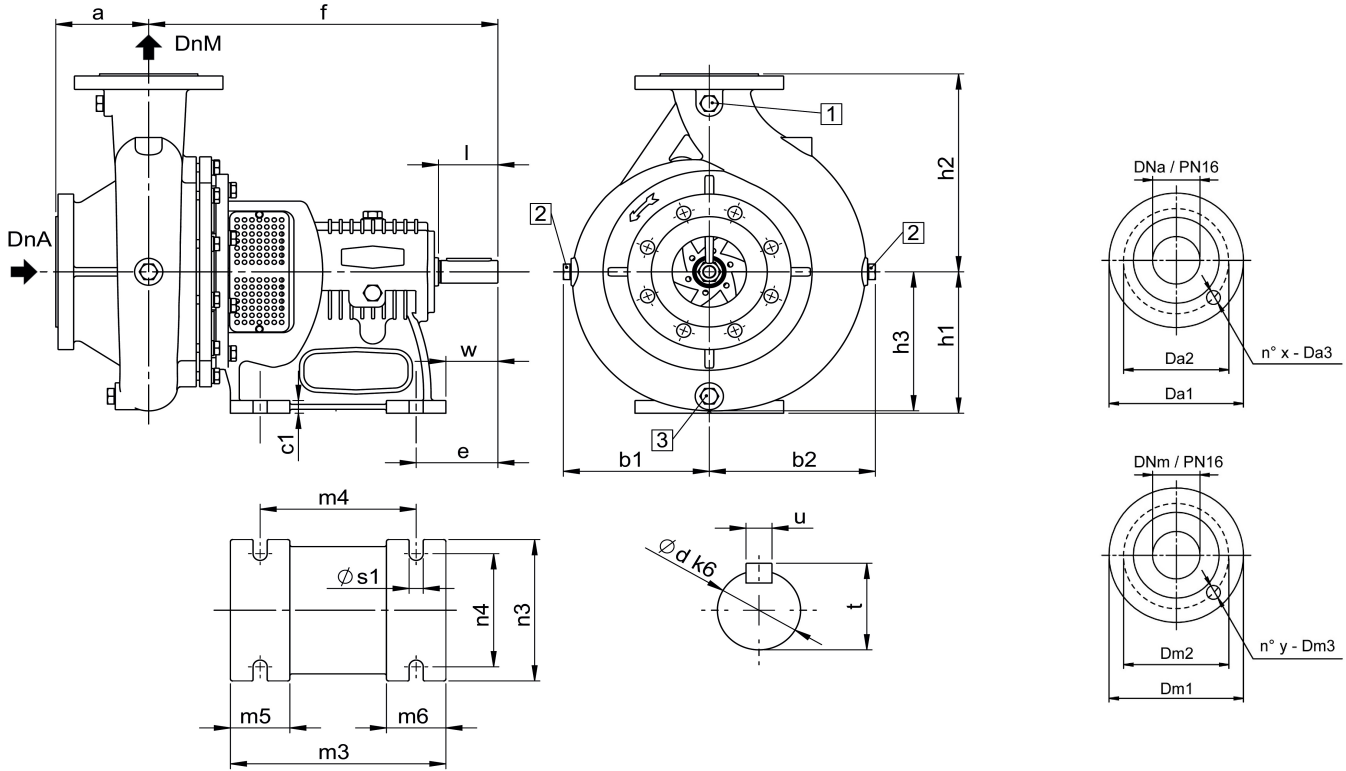

Dimensions in	mm	Total weight	96 kg
DNa	125	u	10
DNm	100	t	35
a	140	1	G 1/4"
b1	195	2	G 1/4"
b2	226	3	G 1/4"
c1	18	Da1	250
f	470	Da2	210
h1	200	Da3	18
h2	280	Dm1	220
h3	211	Dm2	180
m3	290	Dm3	18
m4	210	x	8
m5	80	y	8
m6	80		
n3	200		
n4	160		
s1	19		
e	110		
w	70		
d	32		
l	80		

Technical data

SN3F100-250-E-OB-TB-GG

MEI >= 0,4

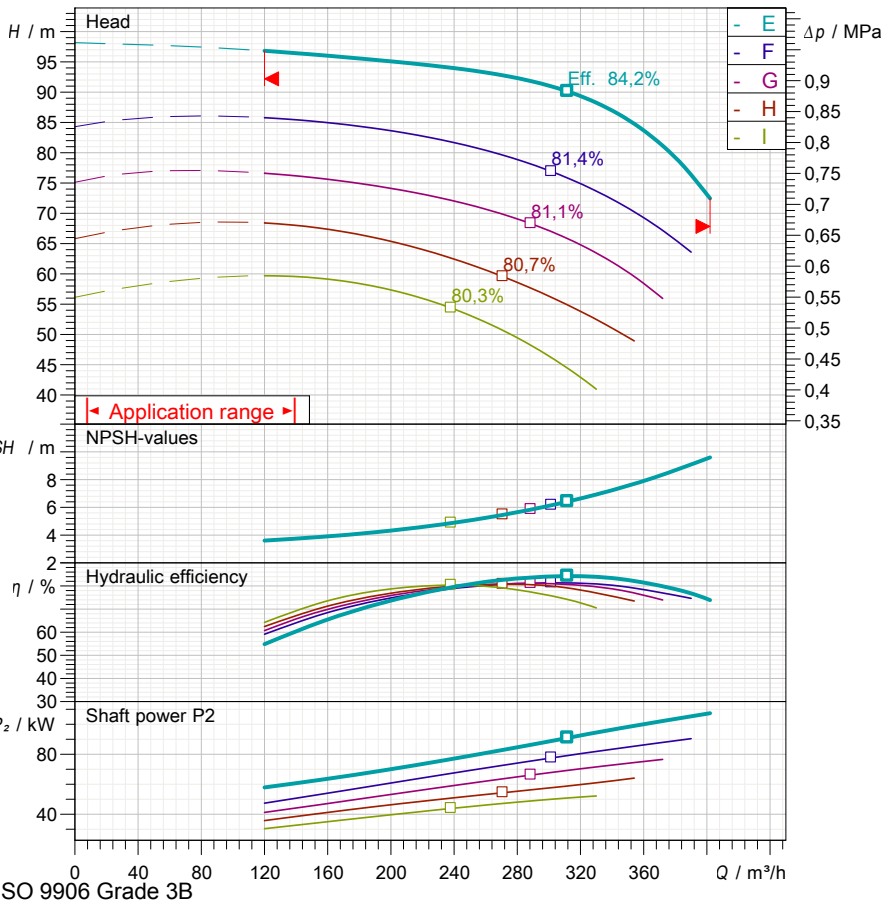

Operating data specification	
Capacity	
Head	
Fluid	Pure water
Type of installation	<Single head pump>

Pump operating data	
Design	SN3F100-250-E-OB-TB-GG
Impeller Ø	270 mm
Speed	2900 1/min
Flow	
Head	
Shaft power P2	
Efficiency	
Head (Q=0)	98,2 m
Non return valve loss	

Electric motor technical data	
Design	
Rated power	
Frequency	
Number of poles	
Nominal speed	
Rated voltage	
Starting mode	
Rated current	
Insulation class	
Degree of protection	

Use limits	
Max N° startings/hour	
Max. runing time with Q=0	2 min
Max. solids contents	60 g/m³
Max. pumped liquid temperature	90 °C
Maximum density	998 kg/m³
Maximum viscosity	1 mm²/s

Materials	
Pump body	Cast iron
Impeller	Carbon steel + Cataphoresis
Wear ring	Cast iron
Support	Cast iron
Bearing support	Cast iron
Shaft	Stainless steel
Twiner system®	Stainless steel
Stuffing-box packing	Synthetic fibers
Shaft protection bushing	Chromed stainless steel

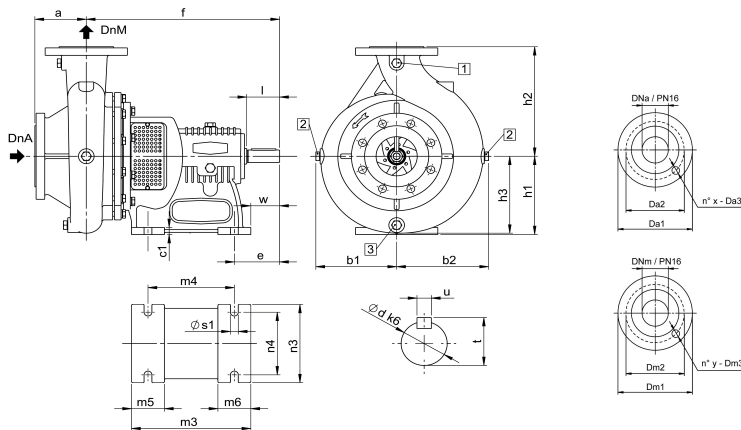

Dimensions in			mm			Total weight			96 kg		
DNa	125	h2	280	s1	19	2	G 1/4"	x	8		
DNm	100	h3	211	e	110	3	G 1/4"	y	8		
a	140	m3	290	w	70	Da1	250				
b1	195	m4	210	d	32	Da2	210				
b2	226	m5	80	l	80	Da3	18				
c1	18	m6	80	u	10	Dm1	220				
f	470	n3	200	t	35	Dm2	180				
h1	200	n4	160	1	G 1/4"	Dm3	18				

Performance curves

SN3F100-250-E-OB-TB-GG

MEI >= 0,4

Performances

Speed	2900 1/min		Density	998 kg/m ³
Flow	Min.	120 m ³ /h	Viscosity	1 mm ² /s
	Max.	402 m ³ /h	Temperature	20 °C
Efficiency	Max.	312 m ³ /h	Tolerances	ISO 9906 Grade 3B

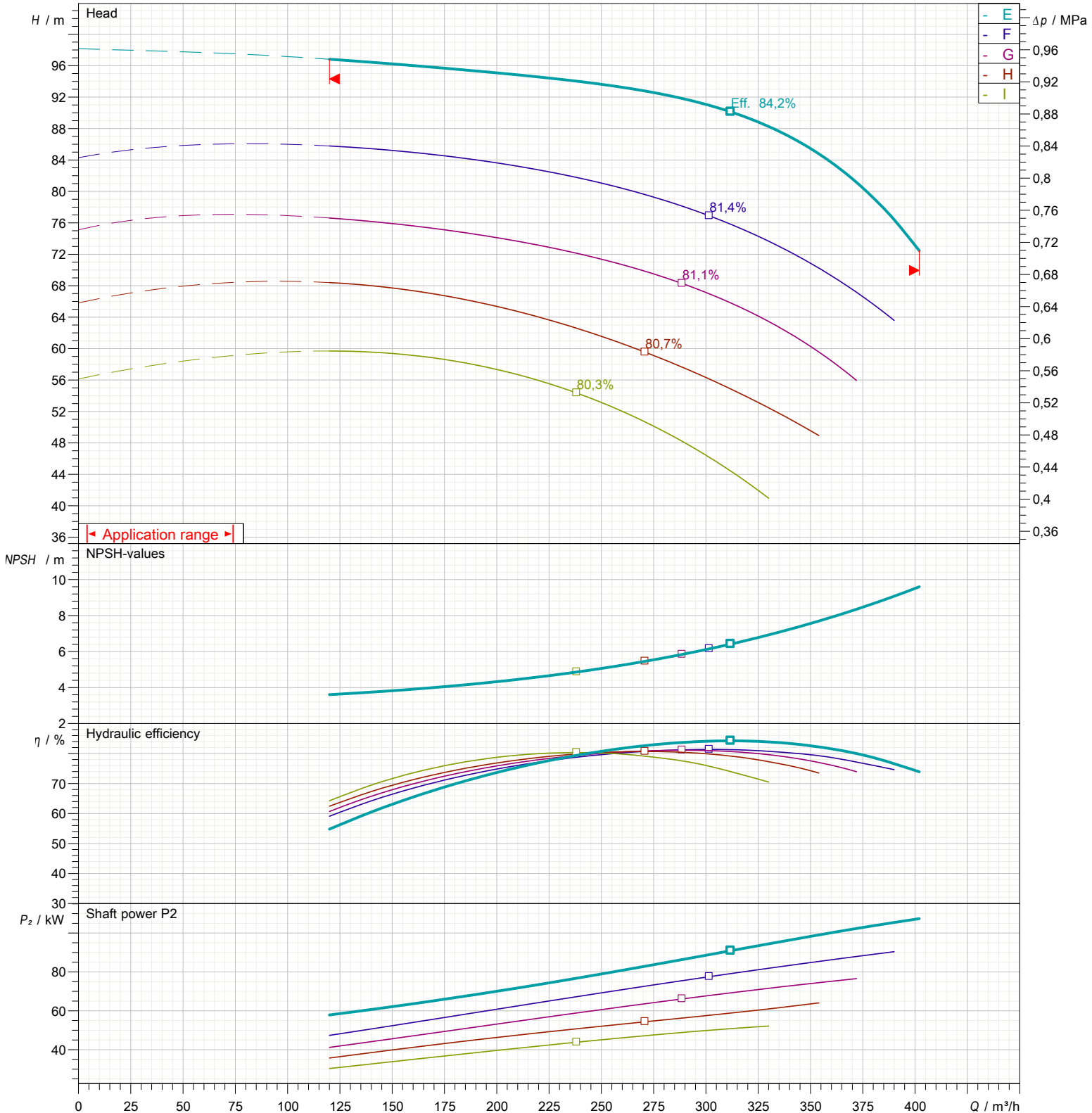

Types of installation

SN3F100-250-E-OB-TB-GG

MEI >= 0,4

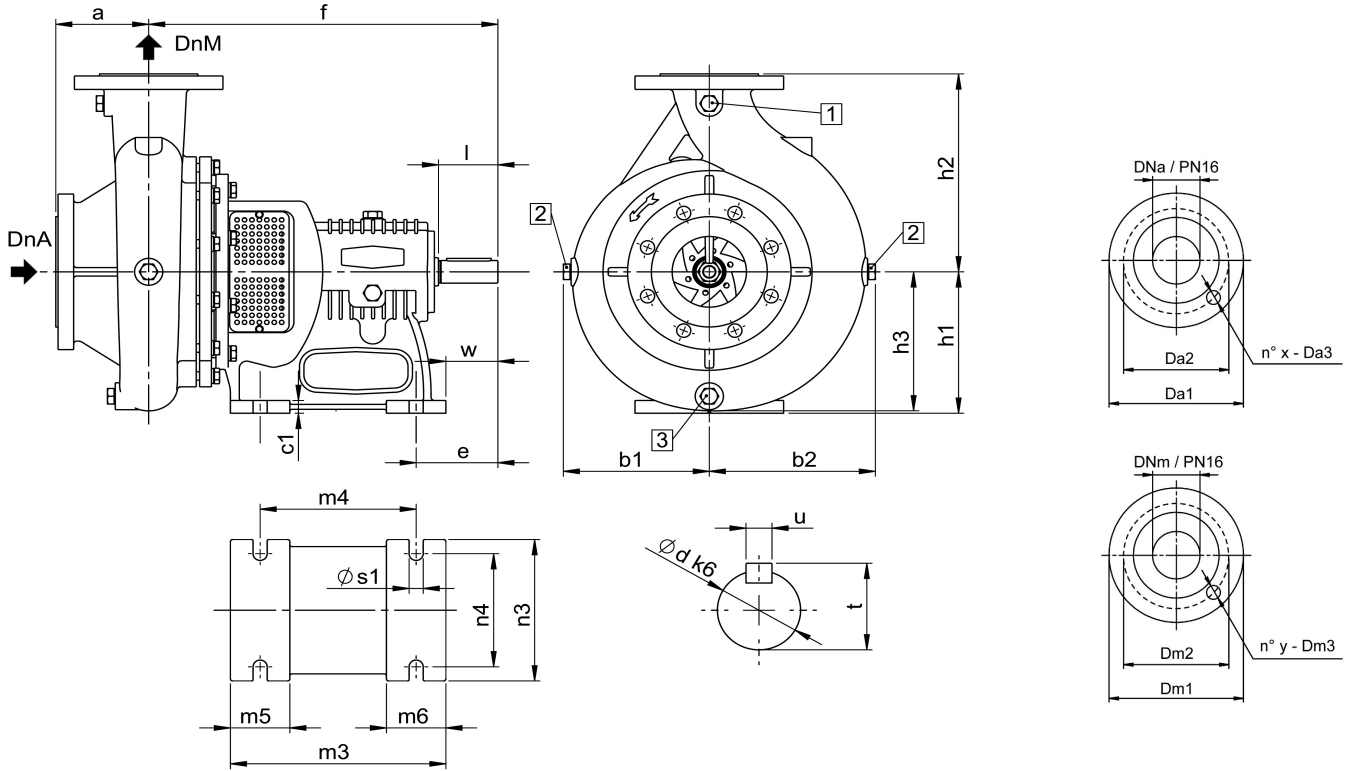

Dimensions in	mm	Total weight	96 kg
DNa	125	u	10
DNm	100	t	35
a	140	1	G 1/4"
b1	195	2	G 1/4"
b2	226	3	G 1/4"
c1	18	Da1	250
f	470	Da2	210
h1	200	Da3	18
h2	280	Dm1	220
h3	211	Dm2	180
m3	290	Dm3	18
m4	210	x	8
m5	80	y	8
m6	80		
n3	200		
n4	160		
s1	19		
e	110		
w	70		
d	32		
l	80		

rovatti pompe

Products you can rely on

Rovatti cataphoresis coating

Cataphoresis is an electrochemical coating process for cast iron components provided by Rovatti Pompe to improve protection from weather conditions, alkali and diluted acids.

Rovatti cataphoresis treatment is characterized by a high adhesion to the surfaces and uniformity of the coating also in the inner cavities of the component.

The result is a black semi-gloss protective layer with homogeneous thickness.

Rovatti cataphoresis treatment produces a reduced surface friction in the hydraulic channels improving pump efficiency and increasing driving motor life.

Components treated with the Rovatti cataphoresis coating are easily removable during the usual maintenance operations.



HEADQUARTERS:
42042 FABBRICO (REGGIO EMILIA)
ITALY
Tel +39 0522 66 50 00
Fax +39 0522 66 50 20
info@rovatti.it
www.rovatti.it

2000 DIVISION:
42047 ROLO (REGGIO EMILIA)
ITALY
Tel +39 0522 66 72 17 / 0522 66 72 25
Fax +39 0522 66 09 79
info@rovatti.it
www.rovatti.it

IPERSOM DIVISION:
42042 FABBRICO (REGGIO EMILIA)
ITALY
Tel +39 0522 66 08 15
Fax +39 0522 66 02 70
info@rovatti.it
www.rovatti.it



rovatti pompe

Products you can rely on

Twinner System®

To make maintenance operation more efficient, it is essential to reduce the time and the cost of any intervention. The exclusive Twinner System® by Rovatti allows to easily operate on gland packing box without removing shaft support.



Available on many pumps of the wide Rovatti production range the Twinner System® consists of:

- Flange in two stainless steel halves that through a simple extraction greatly facilitates the replacing operations of stuffing-box packing.
- Easy to adjust and long-term functioning stuffing-box packing on stainless steel chromium coated bush.
- Stainless steel screws that allow easy disassembling, control and stuffing-box replacement procedures even after several operation hours.



HEADQUARTERS:
42042 FABBRICO (REGGIO EMILIA)
ITALY
Tel +39 0522 66 50 00
Fax +39 0522 66 50 20
info@rovatti.it
www.rovatti.it

2000 DIVISION:
42047 ROLO (REGGIO EMILIA)
ITALY
Tel +39 0522 66 72 17 / 0522 66 72 25
Fax +39 0522 66 09 79
info@rovatti.it
www.rovatti.it

IPERSOM DIVISION:
42042 FABBRICO (REGGIO EMILIA)
ITALY
Tel +39 0522 66 08 15
Fax +39 0522 66 02 70
info@rovatti.it
www.rovatti.it

