



PORTABLE
POWER STATION
WITH SOLAR PANEL INPUT



INSTRUCTION MANUAL

Please read these instructions carefully and retain for future reference.



V1
SWB-8902-BKOR

HIGHLIGHTS

- Overload Protection
- 83 200 mAh output
- Solar Panel Input
- 300 W AC Output
- LED Torch & COB Light

PACKAGE CONTENTS

- Switched 300 W Professional Portable Power Station
- 1 x Adapter
- 1 x Solar Charging Cable
- 1 x car Charging Cable
- 1 x 3 - in - 1 Charging Cable

SPECIFICATIONS

• Battery Capacity	3.7 V 83 200 mAh (307.84 WH)
• Rated Power	300 W
• Peak Power	600 W
• AC Output	230V \pm 10% / 50 HZ
• USB Output	QC3.0 / 18 W
• Type-C Output	PD60 W / PD20W
• DC5525 Output	12 ~ 16.8 V / 8
• Wireless Charging	15 W
• Car Socket	12 ~ 16.8 V
• Net Weight	3.5 kg
• Dimension	273 x 171 x 163 mm
• Torch and COB Lights	LED
• Working Temperature	-10 - 40 °C

IDENTIFYING PARTS



1. LCD Screen Display
2. DC Output
3. Cigarette Lighter Output
4. USB -A Output
5. USB -PD Output
6. DC Input / Car Charging Input
7. PV Input
8. SOS Mode
9. Anti-Collision Strip
10. Folding Handle
11. Wireless Charger
12. Air Intake with Cooling Fan
13. LED Light
14. 300 W Rated AC Output (SA Pins)

BUTTON FEATURE



A. DC Outputs Power ON / OFF Button
B. Power ON / OFF Button
C. LED Light Button

D. USB Output Power ON / OFF Button
E. AC Outputs Power ON / OFF Button
F. SOS Mode

BUTTON FEATURES CONTINUED:

A. DC Outputs Power ON / Off Button

DC Output ports will not function until the unit has been switched on using the Power ON / OFF button.

- Press DC Outputs Power ON / OFF Button to activate and deactivate.

B. Power ON / OFF Button

The Power switch to turn the unit ON and OFF.

C. LED Light Button & F. SOS Mode

SOS Function is available when the unit is ON or OFF.

- Press SOS / LED Button once – SOS Flashlight / LED Light Switches on.
- Press SOS / LED Button twice – SOS Flashlight / LED Light Flashes Fast.
- Press SOS / LED Button Three Times - SOS Flashlight / LED Light Flashes.
SOS MORSE CODE
- Press SOS / LED Button Four Times to switch it off.

D. USB Output Power ON / OFF Button

USB Output ports will not function until the unit has been switched on using the Power ON / OFF button.

- Press USB Output Power ON / OFF Button to activate and deactivate.

E. AC Outputs Power ON / OFF Button

AC Outputs Power Ports will not function until the unit has been switched on using the Power ON / OFF button.

- Press AC Outputs Power ON / OFF Button to activate and deactivate.
- **WIRELESS CHARGER**
- Switch on the unit to activate the wireless charging port. Shut down to deactivate the ports.
- **COOLING FAN**

The unit uses a built-in cooling fan to make sure the product operates within the correct temperature ranges to avoid higher output loads. The fan may start immediately upon starting the product to ensure the product runs smoothly.

LCD SCREEN

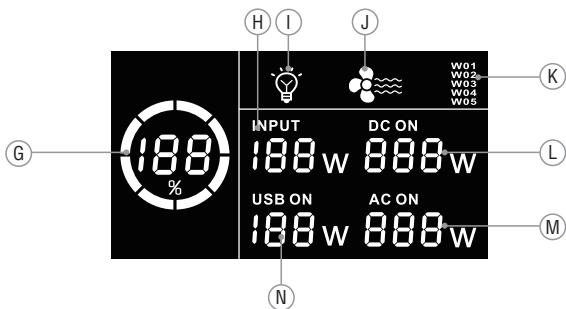
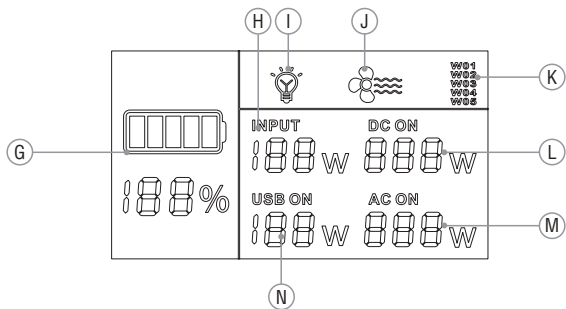

- G. Battery Level Indicator
- H. Input Status
- I. 3LED ON
- J. 3Fan ON

- K. Error Code
- L. DC Outputs Status
- M. AC Outputs Status
- N. USB Outputs Status

LCD SCREEN CONTINUED:

- G. Battery Level Indicator
 - Displays when the unit is switched on.
- H. Input Status displays once the unit is switched and is turned on, charging a device.
- I. LED ON
 - Displays when LED / SOS mode is active.
- J. Fan ON displays on the LCD Screen when it's turned on.
- K. Error Code :
 - W01: Battery High-Temperature Protection
 - W02: Battery Low-Temperature Protection
 - W03: AC Short Circuit Protection
 - W04: Overload Protection
 - W05: Low Voltage Protection
- L. DC Outputs Status displays on the LCD Screen when it's turned on.
- M. AC Outputs Status displays on the LCD Screen when it's turned on.
- N. USB Outputs Status displays on the LCD Screen when it's turned on.

INSTRUCTIONS FOR USE

USING THE SWITCHED PORTABLE POWER STATION

Charging the Switched 300 W Professional Portable Power Station:

- Connect the provided AC wall power adapter to the DC / Car Charging Input
- **Allow Power Station to fully charge before first use. Approx. 5-6 Hours.**
- The LCD Screen will be illuminated, and the Battery Level will display on the Display Screen.

Charging with the Solar Panel

- Connect the Anderson plug to the PV Input.
- **Allow Power Station to fully charge before first use. Approx. 6-9 Hours.**

NOTE: The Red part of the Anderson plug is Positive, and the Black part of the Anderson plug is negative. Make sure you connect the positive with the positive and the negative with the negative for the correct connectivity.

We recommend fully charging your power station every 3 months to maintain the battery's health.

Charging a Device:

- Select the type of outlet you need to charge by selecting either the DC Outputs ON / OFF, USB Outputs ON / OFF or the AC Outputs ON / OFF. The output port will not work unless the correct port is activated.
- When you have activated a port, the sign on the button will illuminate green, indicating that the outputs are active.
- The LCD screen will illuminate and provide details on the output.
- Once you deactivate the outputs, the LCD screen will shut down automatically.

Note: The power station will enter sleep mode after 20 seconds of inactivity, and it will automatically activate once there's a charging cord inserted or when a button is pressed.

Press the ON / OFF to shut down the station when not in use.

Pass-Through Charging

The battery system of the power station allows you to charge a device via **DC Outputs** and **USB Outputs** while the station is charging.

NOTE: DO NOT CONNECT A DEVICE VIA AC OUTPUT WHILE THE STATION IS CHARGING.

Overload Condition

Once an overload occurs on the Output Ports, the Switched 300W Professional Portable Power Station will do the following:

- Automatically disconnect power running to the AC Outlets.
- The blue indicator light of the LCD Screen will remain illuminated.
- DC Outputs Status M will remain as usual.

SAFETY PRECAUTIONS

- Never use your unit near water or in areas where it can come into contact with water.
- Never handle the unit if it is dropped into water or other liquid. This is a safety hazard if the product comes into contact with water while switched off but still plugged in.
- Always ensure your hands are dry before touching the plug or power connections.
- Do not operate the product with a damaged cord or plug after it malfunctions or has been dropped or damaged.
- The unit is for personal use only. Commercial use invalidates the warranty, and the supplier cannot be held responsible for injury or damage caused when using the device for any purpose other than its intended purpose.
- The unit is not intended for use by children, persons with reduced physical, sensory or mental capabilities, or lack of experience and knowledge unless they have been given supervision or instructions concerning the use of the device by a person responsible for their safety.
Extreme caution must be exercised.
- Do not apply excessive force on the cables.
- Do not unplug by pulling the cord.
- Do not place the cord or device near heating elements.
- Do not bend the blade or pins of the plugs.
- Unplug the Switched 300 W Professional Portable Power Station from the AC wall outlet when it is not used.
- While it is being used, do not place the product on a bed, bag or inside anything that is not well ventilated.
- Children should be supervised to ensure they do not play with the Switched 300 W Professional Portable Power Station. Packaging must never be left within reach of children since it is potentially dangerous.

ENVIRONMENTALLY FRIENDLY DISPOSAL

IMPORTANT INFORMATION FOR CORRECT DISPOSAL OF THE PRODUCT IN ACCORDANCE WITH THE EUROPEAN DIRECTIVE ON WASTE ELECTRICAL AND ELECTRONIC EQUIPMENT.

- At the end of its working life, the product must not be disposed of as urban waste. It must be taken to a special local authority differentiated waste collection center or to a dealer providing this service. Disposing of household appliance separately avoids possible negative consequences for the environment and health deriving from inappropriate disposal and enables the constituent materials to be recovered to obtain significant savings in energy and resources. As a reminder of the need to dispose of household appliances separately, the product is marked with a crossed-out wheeled dustbin.
- Never dispose of used electronics with ordinary solid waste since they contain toxic substances.
- Always dispose of used electronics in accordance with the prevailing community regulations that apply to the disposal of electronics. If there are no regulations concerning electronics disposal, please dispose of the device in a waste bin for electronic devices.



 WARNING	Lithium-ion Batteries and/or products that contain Lithium-ion Batteries can expose you to chemicals including cobalt lithium nickel oxide, and nickel, which are known to the State of California to cause cancer and birth defects or other reproductive harm. For more information go to www.P65Warning.ca.gov .
---	--

DISCLAIMER

All product and company names are trademarks™ or registered ® trademarks of their respective holders. Use of them does not imply any affiliation with or endorsement by them. All trademarks and trade names are those of their respective owners.

WARRANTY

This Switched 300 W Professional Portable Power Station includes a standard 12-month limited warranty against manufacturing defects and faults. Should your product be unboxed with any faulty parts, poor finishing visible damage, or fail to perform due to a manufacturing defect or poor workmanship, please return it with your proof of purchase (till slip or invoice) to the store of purchase for an exchange, or repair, depending on the store's returns policy.

This warranty commences from the date of purchase.

Kindly retain your proof of purchase as well as the packaging for your warranty period.

NOTE: The warranty does not apply to a product that:

- a. Has failed due to excessive wear and tear beyond what is considered to be reasonable.
- b. Has been misused or neglected.
- c. Has been damaged accidentally or by Force Majeure, including fire and flooding.
- d. Has been used or operated contrary to operating or maintenance instructions outlined in this manual.

The Store of Purchase / Seller cannot accept any returned products that have not been returned in accordance with this warranty or which do not follow their own Returns Policy. Please refer to the Store of Purchase / Sellers Returns Policy for details.

Please contact the store of purchase if you require further assistance or have any questions about your warranty.