

PRESSURE SYSTEMS CAM60/25



309CAM60/25

APPLICATION

Automatic high pressure groups coupled with self priming jet pumps. They are very silent and reliable and particularly suitable to increase pressure from a water system, to supply water from wells and in domestic high pressure groups.



OPERATING CONDITIONS

- Liquid temperature up to 35°C
- Ambient temperature up to 40°C
- Total suction lift up to 8 m
- Continuous duty

MOTOR

- 2-Pole induction motor (n = 2850 min-1)
- Insulation Class F
- Protection IP44

MATERIALS

- Butyl membrane tank
- Flexible hose with connection
- Adjusted switch on/off pressure 1.6 - 3.2 bar with cable
- Pressure gauge
- Brass connection

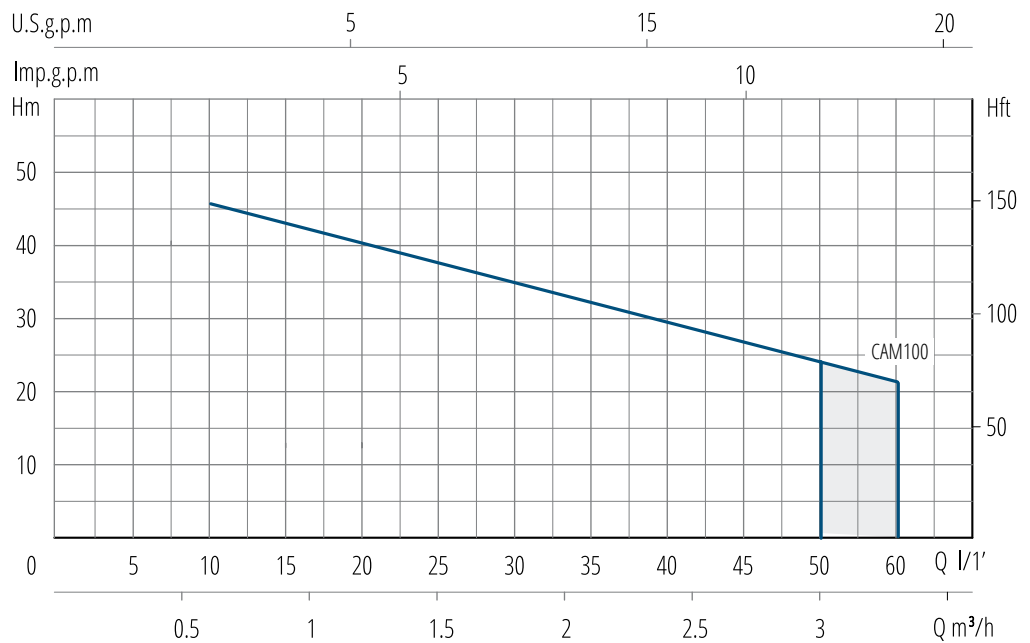

TYPE	NOMINAL POWER		INPUT POWER	AMPERE	Adjusted switch on/off pressure	Q = CAPACITY													
	HP	KW				Single-phase	m³/h	0,6	0,9	1,2	1,5	1,8	2,1	2,4	2,7	3	3,6		
Single-phase	P2		P1	Single-phase	Bar	Total head in meters w.c.													
230V-50Hz	1	0,75	1,1			1 x 230V	H(m)	45	43	40	38	35	33	30	29	26	22		

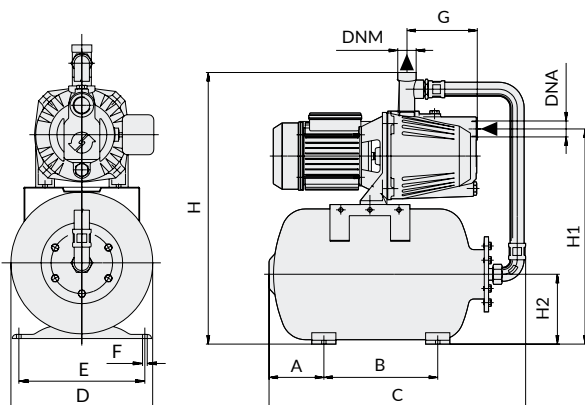

TYPE	DIMENSIONS mm												WEIGHT
Single-phase	A	B	C	D	E	F	G	H	H1	H2	DNA	DNM	kg
CAM100/25	113	235	530	270	240	9	145	560	444	144	1"	1"	22

TROUBLESHOOTING PUMP GUIDE



PROBLEM	CAUSE	ACTION
The pump unit frequently switches on and off, even with a tap/outlet closed.	Non-return valve is dirty or is not installed correctly.	Check if non return is installed correctly or if dirt is preventing it from closing properly.
	The tank bladder is deflated.	Check the "tyre" valve under the black cap on the back of the tank. If no air comes out, disconnect the pump completely and inflate the bladder to 1.5-1.7 bar.
	The tank bladder has burst.	Check the "tyre" valve under the black cap on the back of the tank. If water comes out, replace the bladder.
	The shut-off pressure inside the pressure switch is set too low.	Turn the nut on the small spring on the inside of the pressure switch inwards. Make sure not to exceed the maximum pressure of which the pump is capable.
The pump unit switches on when all outlets are closed.	Water pressure is dropping, causing the pump to switch on.	Check the pressure gauge on the pump unit and confirm that the pressure is dropping, check for a leak in the system.
The pump unit does not switch off.	Not all outlets are closed.	Make sure that all outlets are closed. Check the pressure gauge to confirm.
	Burst or leaking pipe.	Check for leaks.
	Faulty pressure switch.	Ensure that the pressure switch is in working order.
	There is no water coming into the pump.	Make sure that the pump is primed and that water is able to move freely into the pump and that all inlet valves are open.
The pump unit makes a humming sound, but does not switch on.	Faulty capacitor.	Ensure that the capacitor is correctly connected and / or not damaged, replace if necessary.
	The pump shaft is being "trapped" and unable to turn.	Remove the fan cover and fan at the back of the pump motor and ensure that the shaft can turn freely. If not, the possible causes include bearing failure, excessive dirt on the inside of the volute casing or other restrictions in the pump.
The pump switches on, but there is no pressure.	The pump inlet and outlet are incorrectly connected.	Ensure that the water inlet is connected to the inlet of the pump (front connection) and the outlet to the outlet of the pump (top connection).
	Restriction in pipeline.	Check that there are no restrictions in the system that would prevent water from flowing.
	Broken, blocked or faulty impeller.	Open the volute casing and ensure that the impeller is not faulty.
	There is no water coming into the pump.	Make sure that the pump is primed and that water is able to move freely into the pump and that all inlet valves are open.
Water is leaking out between the pump and motor of the unit.	Faulty mechanical seal.	Replace the mechanical seal.
Grinding noise originating from the motor of the pump unit.	Bearing failure.	Replace the motor bearings. Bearing failure is often caused by mechanical seal failure.
The pump unit does not switch on at all.	No incoming power to the pump.	Ensure that the pump is plugged in and switched on.
	Faulty pressure switch.	Ensure that the pressure switch is in working condition.
	"Burnt out" motor.	Test the motor windings and ensure that the motor is in working condition.