

# SB10 | VERTICAL PUMPS 380 V



303SB10-2 · 303SB10-3 · 303SB10-4 · 303SB10-5 · 303SB10-8 · 303SB10-12 · 303SB10-14 · 303SB10-18 · 303SB10-22



The SB, SBI and SBN pumps are non-self priming vertical multistage pump of in-line design, flange or with Victaulic coupling with equally sized suction and discharge ports.

## APPLICATION

- Water supply & pressure boosting
- Irrigation & agriculture
- Water treatment & light industry
- Heating, ventilation & air conditioning

## OPERATING CONDITIONS

- Liquid temperatures from -15°C to +120°C
- Max ambient temperature: +50°C
- Max operating pressure: 25 bar

## MOTOR

- Insulation Class F
- Protection IP55

## MATERIALS

- Shaft - Stainless Steel
- Impeller - Stainless Steel
- Mechanical Seal - Silicon Carbide/Silicon Carbide/EPDM

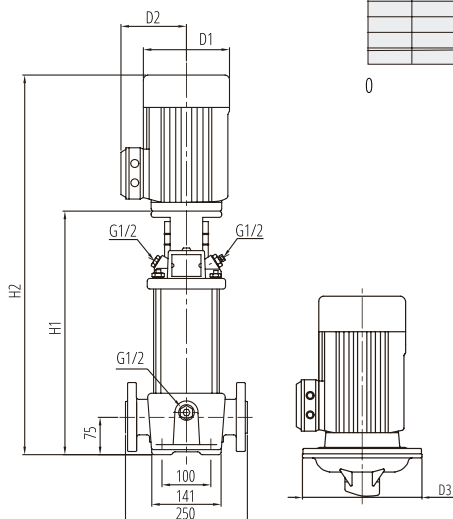
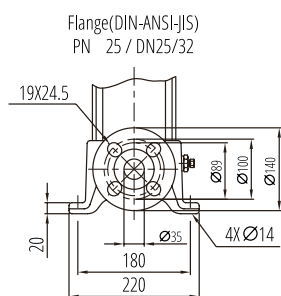
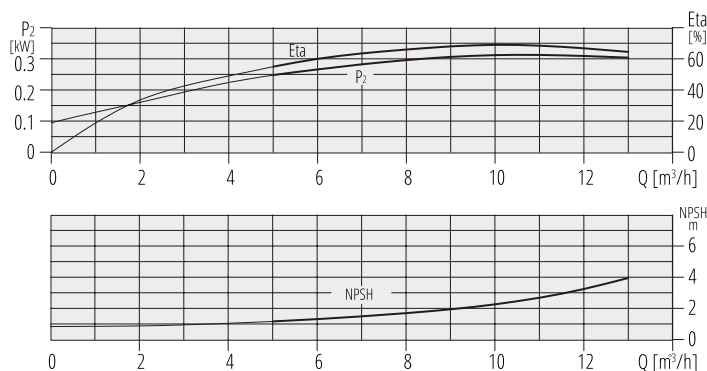
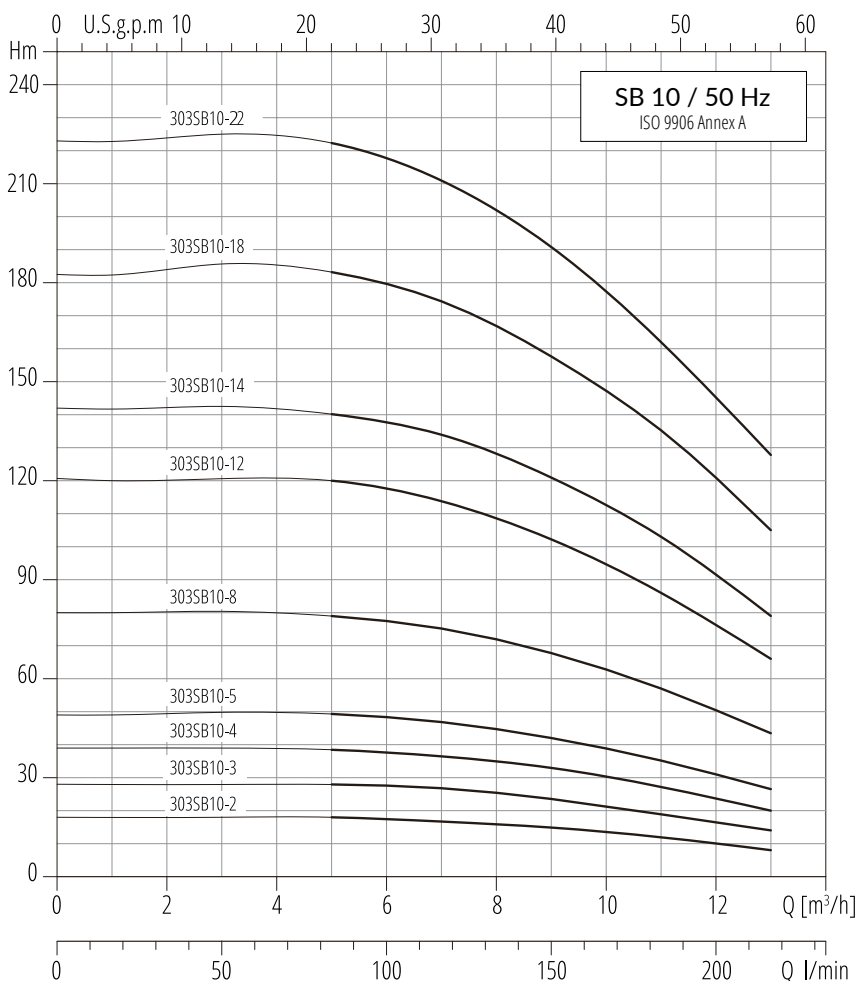

TYPE	MOTOR P2 kW	DIMENSIONS mm			WEIGHT kg	
		DIN flange H1 H2	D1	D2	D3	DIN flange
303SB10-2	0.75	347 582	141	115	-	38.2
303SB10-3	1.1	377 612	141	115	-	40.3
303SB10-4	1.5	423 714	177	141	-	50.1
303SB10-5	2.2	453 744	177	141	-	53.9
303SB10-8	3	548 864	197	147	-	64.9
303SB10-12	4	668 994	220	161	-	72.4
303SB10-14	5.5	760 1122	235	197	300	104.1
303SB10-18	7.5	880 1278	235	197	300	113.6
303SB10-22	7.5	1000 1398	235	197	300	118.8